

Computer Sports Medicine, Inc., (CSMi)

HUMAC®/NORM™
TESTING & REHABILITATION SYSTEM

User's Guide
Model 502140

*Copyright ©2014 Computer Sports Medicine, Inc.
101 Tosca Drive, Stoughton, MA 02072 USA
All Rights Reserved*

Disclaimer:

CSMi makes no representation or warranties regarding the contents of this manual. We reserve the right to revise this document at any time or to make changes to the product described within it without notice or obligation to notify any person of such revisions or changes.

Printed in the United States of America
Part No.: 300004 Rev: E



Medical Device Reporting (MDR)

MDR is intended to provide the Food and Drug Administration (FDA) with the necessary information to assure product safety without imposing an unreasonable burden on device manufacturers and importers.

In accordance with FDA regulations, original equipment manufacturers (OEM) and importers of medical devices are required to report to the FDA whenever the OEM or importer receives or becomes aware of information suggesting that one of its marketed devices may have caused or contributed to a death or serious injury. Also, the OEM and importer(s) are required to report to the FDA if one of their devices has malfunctioned, and a recurrence of that malfunction would be likely to cause or contribute to a death or serious injury.

An injury is considered "serious" if it is life threatening or results in permanent impairment of a body function or permanent damage to a body structure. A "serious injury" is also defined as an injury requiring medical or surgical intervention to preclude permanent impairment of a body function or permanent damage to a body structure, or to relieve unanticipated temporary impairment of body function or unanticipated temporary damage to a body structure

Please contact the CSMi Quality Assurance Department to report any such stated incidence.

The CSMi NORM™ and TMC Systems are designed to be operated with software that is installed at the time of shipment. Any additional software not authorized by CSMi, that is added to the factory installed program, is done at the user's risk and may cause service problems not covered by the customer's warranty.

The software used to operate either system is protected under copyright laws. Any use of the software other than its intended use with the CSMi 6000 or NORM™ Testing and Rehabilitation System is prohibited. Altering or tampering of the software in any manner constitutes an unwarranted use of the NORM system and immediately voids all warranties expressed or implied by CSMi. CSMi assumes no liability for damaged equipment or harm to any individual as a result of malfunction due to tampered software.

Trademark Note:

HUMAC® and NORM™ are registered trademarks of Computer Sports Medicine, Inc.; Microsoft is a trademark and Windows is a trademark of Microsoft Corporation.

IMPORTANT INFORMATION

Qualified Personnel Notice

WARNING: The NORM System contains no user serviceable parts. Installation, Assembly and Repair of the NORM Testing & Rehabilitation System should only be performed by qualified service personnel.

Classification Information

- The NORM is Testing and Rehabilitation System is ELT Listed and CE Certified.
- The NORM System has been classified for use in accordance with the following sections of the Standards for Medical Electrical Equipment:
 - IEC 60601-1 (1988), 'Medical Electrical Equipment, Part 1: General Requirements for Safety' + A1(91) + A2(95).
 - EN 60601-1 (1990), 'Medical Electrical Equipment, Part 1: General Requirements for Safety' + A1(93) + A2(95) UL 60601-1 (2003), 'Medical Electrical Equipment, Part 1: General Requirements for Safety'.
 - CAN/CSA C22.2 No 601.1-M90 (1990), 'Medical Electrical Equipment, Part 1: General Requirements for Safety'.
 - IEC 60601-1-1 (2000), 2nd Edition, 'Medical Electrical Equipment Part 1: General Requirements for Safety - Collateral Standard: Safety Requirements for Medical Electrical Systems'.
 - CB Scheme.
- The NORM System is rated as Class I, Type B as indicated by the  icon located on the Transformer box rating label.

Cleaning and Maintenance

CAUTION: Do not use Benzene, thinner, or any volatile substance to clean the unit as they may leave a permanent mark. Never leave the unit in contact with rubber or vinyl for an extended period.

- Mechanical parts which contact the patient that appear rusted or cannot be cleaned should be replaced.
- Clean/Sterilize removable mechanical parts only.

Upholstery: Use a cloth dampened with a mild household cleaner after each use.

Straps: The belts used on the NORM absorb large and repetitive loads. To ensure patient safety, it is important to check regularly for signs of wear. Any belt with significant wear should be immediately replaced. Keeping extra shin pads and stabilization belts on hand ensures timely replacement and avoids possible injury or down-time.

- The Calibration procedure should be run once per month to assure accurate measurements.

- The user is responsible for disposal of any NORM components per local regulations.

Assembly and Installation Notes

- The NORM System can be installed in any Ordinary Location.
- The system should be installed in such a way that the User is able to carry out the necessary cleaning, and where applicable the sterilization and disinfection measures as specified in this document.
- Do not attempt to lift the NORM Electronics Module or Patient Positioning Module. When it is necessary to move either of these sections, use an appropriate leverage tool such as a Johnson Bar or a long (approximately 4 foot) sturdy piece of wood to act as a lever with another block of wood to act as the fulcrum. To move either Module, insert a leverage tool anywhere under the perimeter of its base frame and “walk” the module into position. Exercise extreme caution when lifting the NORM unit in this manner so as not to “drop” the unit, doing so could damage the electronics. Take care NOT to place your feet near the module base frame.

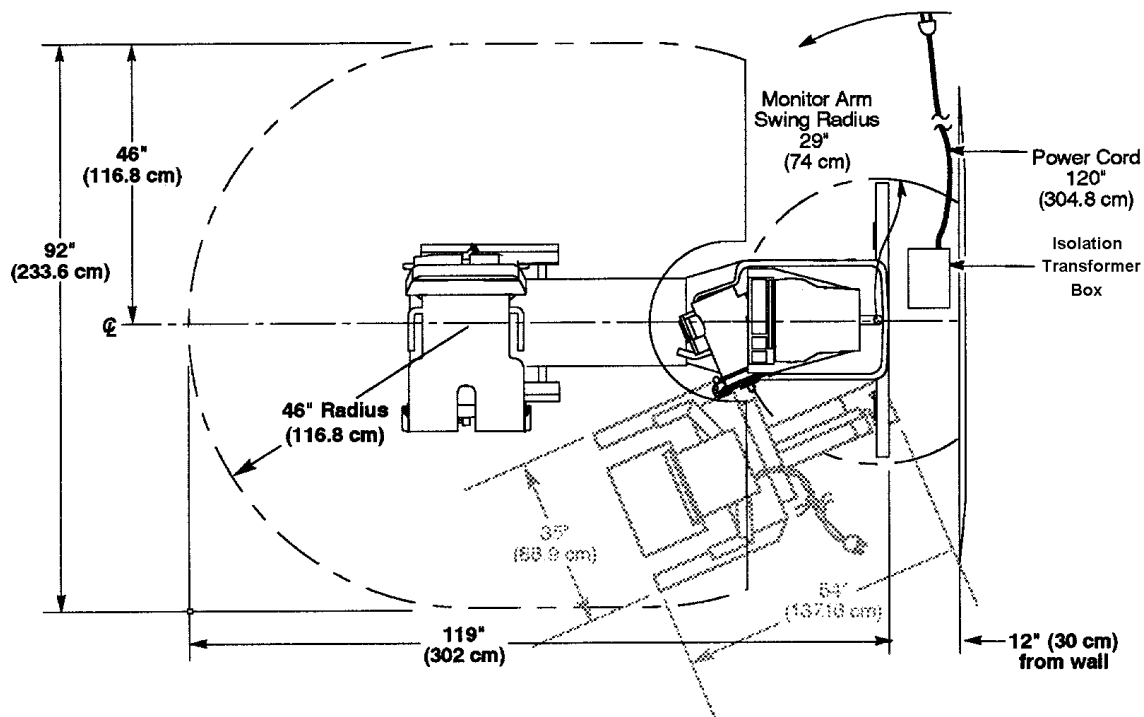

Ratings

- The NORM System is not intended for use in the presence of flammable anesthetics.
- The NORM System is rated for Continuous Operation.
- Operating Temperature 10° Centigrade to 35° Centigrade.
- Storage Temperature -10° Centigrade to 55° Centigrade.
- Operating Relative Humidity 20% noncondensing to 80% noncondensing.
- Storage Relative Humidity 20% noncondensing to 80% noncondensing.

- Special cooling is not required for the operation of the TMC.

Note: It is not recommended that the NORM be changed in any way. If any changes are made, adherence to the CE standards becomes the owner's responsibility, if you have any questions, please contact the CSMi Customer Services Department at: (Voice) 781-297-2034 or (FAX) 781-297-2039 or (e-mail) service@csmisolutions.com.

Electrical Connections Notes

- The NORM System is factory wired for 208 VAC.
- The NORM System must be plugged into the Isolation Transformer Box ONLY. After connecting to the Isolation Transformer Box, replace the receptacle cover bracket over the plugs.

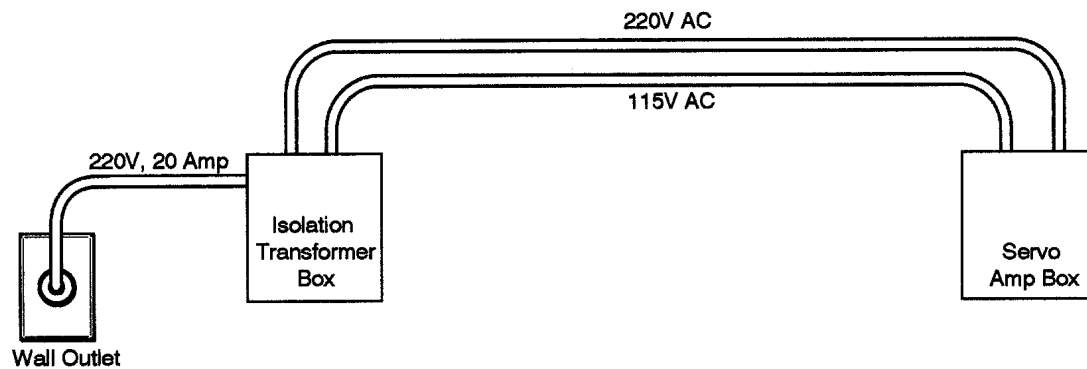

- Both NORM system A/C Cables MUST be plugged into the NORM Isolation Transformer ONLY.
- Only the NORM system A/C Cables are to be plugged into the NORM Isolation Transformer.

WARNING: To avoid risk of electric shock, this equipment must only be connected to a supply mains with protective earth"

Additional multiple portable socket outlet or extension cord shall not be connected to the system.

Do not connect items which are not specified as part of the system.



The multiple outlets on the Servo Amplifier Module are connected in parallel. The following ratings apply.

115V 
 1Ø
 50/60 Hz
 5A Max across all outlets

The following ratings apply to the isolation transformer.

200/208/220/230/240 V 
 1Ø
 50/60 HZ
 10A







Any changes made to the transformer configuration must be done by a qualified technician.

The switch on the NORM Isolation Transformer Box is a circuit breaker. NORM Systems should be powered On or Off with the switch located on the NORM System's electronic module housing.

Perform the following procedure before installing replacement parts and prior to removing any cabinet and system enclosures.

1. Refer to NORM User's Guide manual to exit the NORM application.
2. Turn NORM system Main Power Switch on Servo Amp Box to OFF position.
3. Disconnect Isolation Transformer 230V power cable from its 20 amp wall outlet.
4. Place Isolation Transformer circuit breaker to OFF (down) position.
5. Disconnect the TMC power cable from its wall outlet.

Labels

Symbol	IEC Publication	Description
	417-5032	Alternating Current
	417-5019	Protective earth (ground)
	417-5017	Earth (ground)
	348	Attention, consult accompanying documents
	417-5008	Off (power: disconnection from the mains)
	417 - 5009	Stand-by
	417-5007	On (power: connection of the mains)

IMPORTANT INFORMATION









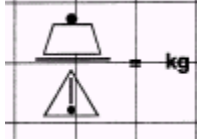

Symbol	IEC Publication	Description
	417-5265	"Off" (only for a part of equipment)
	417-5264	"On" (only for a part of equipment)
	417-...878-02-02	Type B applied part
	60601-2-38	Weight Limits on support parts
	878-5110	Emergency Switch
	ISO 7000-1641	Operator should optionally refer to the accompany documents for additional advice.
	60878	Operator must refer to the accompany documents for additional advice.
		WEES directive
		Temperature Limits
		Humidity Limits
		Pressure Limits

TABLE OF CONTENTS

SECTION 1. CLINICAL ASPECTS..... 1-1

 HUMAC NORM SYSTEM USAGE 1-2

 MEDICAL/LEGAL ASPECTS OF BACK TESTING..... 1-6

 ISOKINETICS AND THE HUMAC NORM SYSTEM 1-9

 CONTRAINDICATIONS..... 1-13

 DESCRIBING JOINT POSITION IN THE RANGE OF MOTION 1-17

 DETERMINING TEST SPEEDS (HIGHLY ACTIVE VS TYPICAL ORTHOPEDIC PATIENTS) 1-18

 RATIONALE FOR STANDARDIZED RULES AND PROTOCOLS..... 1-20

 SETTING REHABILITATION GOALS 1-23

 CLINICAL APPLICATIONS OF RANGE LIMITING 1-27

 CORRECT LENGTH ADJUSTMENT OF INPUT ACCESSORIES 1-29

 EFFECT OF GRAVITY (on Testing Procedures and Results) 1-31

 CONSIDERATIONS FOR ECCENTRIC APPLICATIONS 1-33

 ISOMETRIC APPLICATIONS 1-34

SECTION 2. MECHANICAL OVERVIEW..... 2-1

 BASIC CONFIGURATION AND SPECIFICATIONS 2-2

 THE ELECTRONICS PANEL 2-5

 SYSTEM POWER-UP 2-5

 NORM SYSTEM PARTS AND COMPONENTS 2-7

 DYNAMOMETER POSITIONING 2-10

 USING INPUT ADAPTERS 2-12

 THE RECLINING CHAIR 2-13

 ADJUSTING THE RECLINING CHAIR..... 2-14

 STABILIZATION ACCESSORIES..... 2-17

SECTION 3. PATTERN SELECTION AND SETUP 3-1

 TESTING AND EXERCISE OF THE KNEE 3-2

 KNEE: EXTENSION/FLEXION (SEATED)..... 3-4

 KNEE: EXTENSION/FLEXION (PRONE)..... 3-6

 KNEE: TIBIAL INTERNAL/EXTERNAL ROTATION 3-8

 TESTING AND EXERCISE OF THE ANKLE 3-10

TABLE OF CONTENTS

ANKLE: PLANTAR/DORSIFLEXION (PRONE)	3-12
ANKLE: PLANTAR/DORSIFLEXION (SUPINE).....	3-14
ANKLE: INVERSION/EVERSION	3-16
TESTING AND EXERCISE OF THE SHOULDER.....	3-18
SHOULDER: ABDUCTION/ADDUCTION.....	3-21
SHOULDER: EXTENSION/FLEXION	3-23
SHOULDER: HORIZONTAL ABDUCTION/ADDUCTION.....	3-25
PNF D1: FLEXION-ADDUCTION/EXTENSION-ABDUCTION	3-27
PNF D2: FLEXION-ABDUCTION/EXTENSION-ADDUCTION	3-29
SHOULDER: INTERNAL/EXTERNAL ROTATION IN 90° ABDUCTION	3-31
SHOULDER: INTERNAL/EXTERNAL ROTATION (MODIFIED NEUTRAL POSITION - STANDING).....	3-33
SHOULDER: INTERNAL/EXTERNAL ROTATION, MOD - SEATED).....	3-35
SHOULDER: INTERNAL/EXTERNAL ROTATION IN 90 DEG FLEXION.....	3-37
TESTING AND EXERCISE OF THE WRIST AND FOREARM	3-39
TESTING AND EXERCISE OF THE ELBOW	3-40
FOREARM: PRONATION/SUPINATION	3-41
WRIST: EXTENSION/FLEXION.....	3-43
WRIST: RADIAL/ULNAR DEVIATION.....	3-45
ELBOW: EXTENSION/FLEXION	3-47
TESTING AND EXERCISE OF THE HIP.....	3-49
HIP: ABDUCTION/ADDUCTION	3-50
HIP: FLEXION/EXTENSION	3-52
HIP: INTERNAL/EXTERNAL ROTATION	3-54
TESTING AND EXERCISE OF THE TRUNK	3-56
TRUNK: FLEXION/EXTENSION.....	3-65
APPENDIX A. REPLACEMENT PARTS.....	A-1
NORM SYSTEM ADAPTERS	A-3
NORM ACCESSORIES	A-28
CONSUMMABLE PARTS	A-28
DOCUMENTATION.....	A-28
SOFTWARE.....	A-28
HARDWARE	A-29

TABLE OF CONTENTS

OPTIONS	A-29
THE JOHNSON ANTI-SHEAR ACCESSORY	A-30
WORKSIM ADAPTERS AND ACCESSORIES	A-32
UNIVERSAL WORKSIM ARM	A-34
STEERING WHEEL / VALVE ADAPTER.....	A-36
HANDLES AND KNOBS	A-38
MULTI-GRIP / SCREWDRIVER ADAPTER MULTI-GRIP / SCREWDRIVER AND UNIVERSAL TOOL ADAPTERS	A-40
STATIONARY GRIPPER ARM.....	A-42
GRIPPING DEVICE AND HANDLES.....	A-44
PUSH / PULL INPUT ARM.....	A-46
SIMULATION HANDLE.....	A-48
TEF MODULAR COMPONENT – P/N 731A001	A-50
APPENDIX B. ELECTROMAGNETIC COMPATIBILITY	B-1
GUIDANCE AND MANUFACTURER’S DECLARATION – EMISSIONS.....	B-1
GUIDANCE AND MANUFACTURER’S DECLARATION – IMMUNITY ALL EQUIPMENT AND SYSTEMS	B-2
GUIDANCE AND MANUFACTURER’S DECLARATION – EMISSIONS EQUIPMENT AND SYSTEMS THAT ARE NOT LIFE-SUPPORTING	B-3
RECOMMENDED SEPARATION DISTANCES BETWEEN PORTABLE AND MOBILE RF COMMUNICATIONS EQUIPMENT AND THE NORM EQUIPMENT AND SYSTEMS THAT ARE NOT LIFE-SUPPORTING.....	B-4

LIST OF FIGURES

Figure 1-1. Planes of Motion1-17

Figure 2-1 NORM System Overview2-4

Figure 2-2 Major Mechanical Components.....2-6

Figure 2-3 Adapter and Accessories.....2-9

Figure 2-4 Dynamometer Scales2-10

Figure 2-5 Dynamometer Input Arm.....2-12

Figure 2-6 Reclining Chair Adjustment Scales.....2-13

Figure 2-7 Contralateral Limb Stabilizer & Handle Bars2-17

Figure 2-8 Seat Belt Adjustment2-18

Figure 2-9 Shoulder Stabilization Belts2-18

Figure 3-1 Knee: Extension/Flexion - Seated.3-5

Figure 3-2 Knee: Extension/Flexion - Prone.3-7

Figure 3-3 Knee: Tibial Internal/External Rotation.3-9

Figure 3-4 Ankle: Planter/Dorsiflexion Prone.....3-13

Figure 3-5 Ankle: Planter/Dorsiflexion Supine.3-15

Figure 3-6 Ankle: Inversion/Eversion.....3-17

Figure 3-7 Shoulder: Abduction/Adduction.....3-22

Figure 3-8 Shoulder: Extension/Flexion.....3-24

Figure 3-9 Shoulder: Horizontal Abduction/Adduction.3-26

Figure 3-10 PNF D1: Flexion-Adduction/Extension-Abduction.....3-28

Figure 3-11 PNF D2: Flexion-Abduction/Extension-Adduction.....3-30

Figure 3-12 Shoulder: Internal/External Rotation in 90° Abduction.3-32

Figure 3-13 Shoulder: Internal/External Rotation, Mod - Standing.3-34

Figure 3-14 Shoulder: Internal/External Rotation, Mod - Seated.3-36

LIST OF FIGURES

<i>Figure 3-15 Shoulder: Internal/External Rotation in 90° Flexion.</i>	3-38
<i>Figure 3-16 Forearm: Pronation/Supination</i>	3-42
<i>Figure 3-17 Wrist: Extension/Flexion</i>	3-44
<i>Figure 3-18 Wrist: Radial/Ulnar Deviation</i>	3-46
<i>Figure 3-19 Elbow: Extension/Flexion.</i>	3-48
<i>Figure 3-20 Hip: Abduction/Adduction.</i>	3-51
<i>Figure 3-21 Hip: Flexion/Extension.</i>	3-53
<i>Figure 3-22 Hip: Internal/External Rotation.</i>	3-55
<i>Figure 3-23 Trunk: Flexion/Extension</i>	3-67
Figure 3-24 NORM System Adapters	A-2
Figure 3-25 Elbow and Shoulder Adapter (P/N7700S780)	A-4
Figure 3-26 Contralateral Limb Stabilizer (P/N 7700A240).....	A-6
Figure 3-27 Wrist and Shoulder Adapter Assembly (P/N 7700S960)	A-8
Figure 3-28 Thigh Stabilization Adapter Assembly (P/N 7300S950).....	A-10
Figure 3-29 Foot Rest Assembly (P/N 7700S845)	A-12
Figure 3-30 Elbow Support Subassembly (P/N 7700S915)	A-14
Figure 3-31 Forearm Stabilization Adapter (P/N 7700A850).....	A-16
Figure 3-32 Ankle Adapter Assembly (P/N 7700S886)	A-18
Figure 3-33 Stabilizer Tube Adapter (P/N 7700S865)	A-20
Figure 3-34 Knee and Hip Adapter (P/N 7700A814).....	A-22
Figure 3-35 Shin Pad Adapter (P/N 7700A804).....	A-24
Figure 3-36 Accessory Cart (P/N 7700F090).....	A-26
Figure 3-37 The Johnson Anti-Shear Accessory	A-30
Figure 3-38 Work Simulation Adapters and Accessories	A-32
Figure 3-39 Universal WorkSim Arm.....	A-34

LIST OF FIGURES

Figure 3-40 Steering Wheel / Valve Adapter	A-36
Figure 3-41 Handles and Knobs	A-38
Figure 3-42 Multi-Grip / Screwdriver and Universal Tool Adapters	A-40
Figure 3-43 Stationary Gripper Arm.....	A-42
Figure 3-44 Gripping Device and Handles.....	A-44
Figure 3-45 Push / Pull Input Arm.....	A-46
Figure 3-46 Simulation Handle.....	A-48
Figure 3-47 TEF Modular Component.....	A-50

SECTION 1. CLINICAL APSECTS

This chapter presents the necessary information to make educated clinical decisions regarding the testing and exercise of clients on the HUMAC NORM Testing and Rehabilitation System.

The HUMAC NORM and its various function and capabilities are introduced. The isokinetic theory is also presented as it the necessary information to determine just when, and in what manner, testing and exercise can take place.

Special clinical applications of range limiting are discussed so they may be used in the most effective manner currently available.

HUMAC NORM SYSTEM USAGE

The NORM System is a unique, single chair rehabilitation and testing system used to diagnose and treat orthopaedic patient muscle/joint performance.

NORM isolated-joint testing and rehabilitation systems have proven extremely valuable for quantification and rehabilitation of physical impairment. Additionally, they have been used in clinical research and for gathering human performance data.

Designed to be adaptable to patient needs as well as a clinician's own treatment methods and ideas, the NORM System provides anatomically correct positioning and positive stabilization for testing of the musculature surrounding the shoulder, elbow, forearm, wrist, ankle, knee and hip. Test and exercise speeds ranging from 1 to 500 deg/sec are selectable as protocol requires. Range of motion is controlled by the computer and visible secondary, mechanical range of motion stops. The high resolution, full color graphics display monitor may be used to provide the patient with visual feedback.

This manual contains important information about the safe and efficient use of the NORM System. Clinical applications are also discussed. Please read it thoroughly before using this equipment. It is recommended that each movement pattern (as described in the Pattern Selection and Set-up Chapter) be tried at the suggested test speeds before working with patients.

If there are any questions about the NORM System please call your regional sales representative, CSMI Customer Relations, or a CSMI Clinical Education Specialist.

Responsibility for Safe Testing and Exercise

Thousands of hours of research and literally millions of patient tests and treatments have proven CSMI isokinetic equipment to be among the safest means for musculoskeletal testing and exercise. Risks inherent to free weights, weight machines, calisthenics and other isotonic methods are virtually eliminated by the instantaneous accommodation of isokinetics to pain or fatigue. This does not mean, however, that CSMI equipment should be used unsupervised or without the same evaluation, consideration of specific patient limitations, and degree of supervision applied to the use of other modalities and programs.

Note: *All patients should undergo a full objective and subjective examination prior to the first testing or exercise bout. Subjective evaluations should be given before testing or exercising a patient on the CSMI System at any time.*

Note that it is important to consider the muscular and cardiovascular capabilities as well as the patient's pathology when choosing the speed, intensity and duration of the test/exercise bout. Careful initial evaluation, testing and supervision will usually uncover any precautions or program modifications necessary to ensure patient safety.

Keep in mind also that some types of injuries and surgical procedures require that joint motion be limited to a specific range, for some part of the rehabilitation program, to avoid further injury or re-injury. It is the clinician's responsibility to identify these risks and provide adequate safeguards. Special accessories (i.e., Range Limiting, ramping, Johnson Anti-Shear Device (optional)) are provided to handle commonly required limitations.

In addition to the previous considerations, be aware that pain-free isokinetic exercise provides an intense muscular workout even when performed sub-maximally. Isokinetics, particularly at fast test/exercise speeds, demands the highest work rate / energy expenditure of which the muscles are capable. It also requires significant cardiovascular capability when large muscles are being exercised. To ensure patient safety and optimal test results, experienced CSMI users make the following recommendations:

- Objective/subjective examination of patient prior to test/exercise to determine any significant limitations.
- Warm-up and appropriate stretching of involved muscle groups before testing or exercise.
- A minimum of three sub-maximal and one maximal trial repetition at each testing/exercise speed to check axis alignment, smoothness of limb motion and patient tolerance, and to familiarize the patient with the requirements of the test/exercise.
- Post-exercise stretching when increased range of motion is an objective.
- Ice, compression and elevation may be indicated after intense workouts or any time that post-exercise effusion may occur.

Considerations for Beginning Treatment

When treating a wide variety of patients, the following questions should be considered:

1. Is the uninjured limb on the dominant or non-dominant side?

Clinical experience and research indicate that the non-dominant lower-limb musculature is commonly approximately 5% weaker (peak slow-speed torque) than the dominant side. Differences in fast-speed torque are often slightly greater. Even greater differences have been observed in upper-body musculature probably because there is no shared weight bearing and because the dominant arm is used for the most demanding activities.

1. Has the capability of the uninjured side decreased because of disuse or interruption of training resulting from the injury?

This is particularly significant among highly conditioned individuals who have been on a regular training program. Research has shown that missing a few days of training can

result in significant decreases in certain performance parameters. Bed rest may cause decreases of up to 3% a day. This factor should be considered when setting rehabilitation and retraining goals.

2. Is the patient's normal musculature capability sufficient for the patient's activities?

If not, in addition to rehabilitating the injured limb, an injury prevention program for both limbs should be recommended.

Clinical Guidelines For Trunk Testing

Effective use of the CSMI TEF Modular Component requires a thorough understanding of the physiologic factors involved. Indications and contraindications relative to musculoskeletal, cardiovascular, neuromuscular and other physical conditions must be carefully assessed by the clinician prior to initiating any test. Therefore, a complete subjective and objective evaluation is necessary to ensure proper and safe use of the equipment and maximum benefits to the patient.

Once this exam is performed, if testing is not absolutely contraindicated, the clinician should conduct an initial isokinetic test. The results will help determine if testing can continue. This initial test is also used to develop the specific parameters of the rehabilitation program.

If contraindications exist, the clinician may want to defer or modify the isokinetic test. Refer to the Initial Isokinetic Test topic for further information.

This topic outlines the factors involved in initial testing and evaluation, as well as in the development of a safe and effective rehabilitation program.

The Subjective/Objective Exam

The factors that should be examined at this stage include:

- Patient history
- Range of motion
- Pain and pain ranges
- Irritability of condition
- General health
- Specific musculoskeletal problems
- Gross strength deficits
- Cardiovascular status

From the results of the subjective/objective exam, the clinician can determine which indications and contraindications exist for that patient.

Patient Information Record Keeping

The clinical implications of efficient record keeping is important in determining the status of a patient.

Body weight, percent body fat, and lean mass may all be reflective of the patient's current state of overall fitness. Body weight is best assessed relative to one's percent body weight as fat. An individual may be "underweight" according to standard height -weight charts yet "over-fat" according to appropriate fat percentages. The converse may also be true for a person with a high body weight yet low proportion of fat. It is important to consider that being overweight or underweight has not been demonstrated to be a predisposing factor to low back pain. Rather, the individual's current body composition status should be viewed relative to changes since his or her injury and future ramifications for fitness improvement.

Resting heart rate and blood pressure are essential parameters to assess before and after each test, particularly if the patient demonstrates a history of high blood pressure, angina, stroke or other cardiovascular difficulties. In addition, heart rate and blood pressure responses help the clinician determine the degree of effort executed by the patient during testing. If the patient is extremely fearful or misinformed as to the proper use of the system, his or her vital signs may reflect little increase from resting levels. Excessively high heart rates, although indicating a maximal effort from the patient, may indicate a depressed capacity for exercise.

The chronic pain or extremely disabled patient may have deconditioned to the point where testing may require cardiovascular stress beyond their present capacity. Stray-Gundersen has determined oxygen uptakes demands of trunk flexion/extension testing in both normal and chronic pain subjects. In a protocol consisting of five repetitions at 30, 60 and 150 degrees per second and 15 repetitions at 120 degrees per second. The consumption (ml-kg-min) was 23.7 ± 1.7 for normal subjects and 14.1 ± 1.2 for chronic pain subjects. These results are within the range of moderate aerobic work for normals and light work for the chronic pain subjects. In the case of an extremely deconditioned patient, testing may be deferred until a more appropriate cardiovascular level is achieved through standard aerobic training modalities.

The physical demands to which your patient intends to return, whether they be work or leisure oriented, will help determine each individuals discharge standard. The patient's overall fitness level, total work values, absolute peak torque, peak torque relative to body weight, average power and endurance ratios must all be weighed against the maximal demands of the patient's working or recreational activities.

MEDICAL/LEGAL ASPECTS OF BACK TESTING

CSMI documentation of extremity function has long been accepted by the legal community as an accurate and objective means of quantifying impairment. Historically, the only objective tests of the low back included x-rays, CT scans, myelograms, MRI and EMG. While these tests aided the physician in some forms of diagnosis, very often the test results were negative, yet the subject exhibited loss of function and complaints of pain. Without quantification of functional impairment, many subjects may have been incorrectly labeled malingerers or symptom magnifiers, when, in fact, their symptoms were both very real and exacerbated by continued inactivity and drug therapy.

The CSMI NORM and TEF Modular Component use the proven-accurate principle of isokinetics to quantify the extent of functional impairment. This objective documentation is admissible in court as part of medical evidence and testimony.

If you are called to court, you may be asked to make an assessment of your patient's level of impairment/disability. The information in your presentation should include *Test Reports, Patient Record Information and Calibration Records*.

Test Reports

These may include both graphic and numeric representations of peak torque, range of motion, work, power and endurance. Initial and subsequent tests should follow the same protocols so that accurate comparisons can be made. The data can be used in conjunction with your evaluation of subjective and objective findings.

When you test patients for legal purposes, the question of their malingering or "displaying inappropriate pain behavior" often arises. Theoretically, a maximal effort during an isokinetic test will result in curves of consistent shapes and sizes. However, there are circumstances in which inconsistent curves may be produced, despite maximal effort by the patient. They are:

- Unfamiliarity with the equipment, test procedure or resistance mechanism.
- Fear of the test.
- Intermittent pain.
- General weakness, resulting in rapid fatigue.
- Physiological symptoms, such as rapid increase in heart rate, causing the subject to decrease effort.
- If inconsistencies are demonstrated, it is advisable to re-test the patient.

Bear in mind that the normative data available were collected using prototype equipment. You will have to use your clinical judgment and your understanding of the subject's job demands to completely determine impairment and disability.

Patient Records

You should keep your patient records up-to-date, clear and concise. Any information in the records not written by you should be initialed by you and dated. Records should contain dates of office visits, telephone calls and consultations; source of the patient visit; the nature of the complaint; results of all examinations; diagnosis, treatment plan and prognosis. Any previous treatments and the subject's response to them should also be recorded. Keep in mind that anything in the patient's record may be read aloud in court.

Calibration Records

CSMI recommends that a calibration verification be performed on both the CSMI NORM System and TEF Modular Component monthly, and that calibration records be maintained. CSMI calibration ensures accurate reproducible data, but the responsibility of performing regular calibration lies with the clinician. If the calibration is not performed and recorded regularly, all isokinetic data may be disregarded as evidence.

You may also wish to use selected articles from the CSMI bibliography that demonstrate the accuracy and reproducibility of CSMI data.

When you testify as an expert witness, it is recommended that, in addition to the above, you:

- State all information objectively.
- Make no ambiguous statements.
- Make no judgmental statements regarding the patient's pain.

CSMI data brings objective measure of function into the legal process of quantifying impairment and demonstrating rehabilitation. Keeping accurate records, using consistent protocols and calibrating the equipment monthly will ensure legal documentation if you are called into court.

CSMI Back Systems and Insurance

Insurance programs were established to provide subscribers with benefits that cover wage replacement, medical care and rehabilitation. Workers compensation benefits cover those who are injured on the job. Claims costs have escalated to the extent that medical indemnity payments are exceeding the amount taken in as premium dollars.

CSMI Extremity Systems have been long accepted as an extremity evaluation and rehabilitation tool by Workers' Compensation and insurance companies. This set the stage for acceptance of CSMI Back Testing and Rehabilitation charges.

Insurance costs can be reduced through the use of CSMI systems. An Aggressive program of back testing and rehabilitation can reduce the number of work days lost, provide the necessary rehabilitation and enable the injured subject to return to work.

For the insurer, the CSMI NORM System with the TEF Modular Component provides:

- Non-invasive scientific technology for assessing trunk strength.
- Rehabilitation of injured or weak musculature.
- Graphic and numeric measurement of patient improvement during therapy.
- Faster return to work with decreased chance of re-injury.

This is the only objective test that provided the insurer with documentation of trunk strength, therapy progress and rehabilitation.

ISOKINETICS AND THE HUMAC NORM SYSTEM

Introduction to Isokinetics

The term isokinetics describes a process in which a body segment accelerates to achieve a pre-selected fixed speed against an accommodating resistance. No matter how much force is exerted by the patient, segment velocity will not exceed the pre-selected speed. As torque is produced in an attempt to overcome the pre-selected speed, the resistance varies to exactly match the force applied at every point in the range of motion. The amount of force applied by the patient can be measured in foot-pounds or Newton-Meters of torque and represented both numerically and graphically. When accurately measured, this can be used as a basis for comparison of test results. CSMI isokinetic testing can thus be used to identify and quantify functional musculoskeletal deficits.

Over 20 years of independent clinical research have proven CSMI isokinetic testing to be accurate, objective, reproducible and safe. Because isokinetic resistance accommodates perfectly to the patient's torque output, the risk of overloading a tested joint is greatly minimized. Any reduction in force output due to pain or weakness results in an immediate reduction of resistance. This reduction is measured and graphed, enabling the clinician to determine where in the range of motion a deficit exists. Additionally, consistency of performance is reflected in the reproducibility of an individual's torque curves. Maximal efforts generally produce uniform curves, whereas submaximal efforts may result in curves of variable shape and amplitude.

More than 1000 published articles, studies and presentations have shown CSMI systems to provide objective measurement of impairment and documentation of rehabilitation effectiveness. For identifying and rehabilitating joint dysfunction, CSMI isokinetic exercise with proper positioning and stabilization has proven extremely effective. Clinical researchers have demonstrated that patients placed on a well planned isokinetic rehabilitation program have exhibited marked improvements in objective physical measurements.

For testing of the shoulder, elbow, forearm, wrist, hip, knee and ankle, as well as back testing, isokinetics provides the only way to load a dynamically contracting muscle(s) to its maximum capability at every point in the range of motion. Additionally, the availability of perfectly accommodating resistance at fast, functional speeds (up to 500 deg/sec) allows the CSMI NORM System to offer maximum efficiency for muscular strength, power and endurance development in conjunction with complete safety of use.

Isokinetic testing can also be used to screen for functional deficits that may predispose individuals to injury. Through the use of normative data, clinicians can correlate CSMI isokinetic testing results with the physical demands of specific populations, jobs and activities. This may enable safe parameters for specific tasks to be defined.

Developing the strength, power and endurance of the musculature surrounding the joint is clinically accepted as an important factor in decreasing patients' symptoms and increasing their

functional capacity. CSMI provides the technology to objectively quantify such parameters, giving the clinician a truly comprehensive profile of his or her patients' progress. This valid, objective and permanent data can then be used as the basis for a systematic, scientific approach to treatment of joint dysfunction. Through the use of safe, reliable and reproducible CSMI isokinetic testing and exercise, patients can be rehabilitated to functional levels before attempting to return to daily activities.

The Benefits of Isokinetic Exercise

The concept of isokinetics was developed by James Perrine in the late 1960's. Since then, there has been a dramatic increase in its use for rehabilitation, performance testing and fitness. Isokinetics is the safest and most efficient method to load a muscle. Because it employs a fixed speed and totally accommodating resistance, isokinetics provides several benefits not found with other forms of resistance exercise:

- **Most efficient use of muscle output** - Unlike isotonics, which can only load a muscle maximally at its weakest point, isokinetics is capable of loading a dynamically contracting muscle maximally throughout the range of motion.
- **Reduced chance of overload injury** - The patient's force output is the sole factor controlling the amount of resistance generated by the machine, so there is less risk of overloading the patient's musculoskeletal system.
- **Accommodation to pain and fatigue** - When the patient encounters a difficult or painful point in the range of motion, he/she can respond with less force and the isokinetic device will immediately decrease the resistance accordingly.
- **Full range of speed for testing and exercise** - Because isokinetic equipment generally provides a wide range of speeds, the clinician can pinpoint specific deficiencies in high or low-speed torque output. Rehabilitation programs can be designed to include a variety of selected speeds.
 - **Fast-twitch fibers** respond more to short-term, high intensity exercise and therefore, are stressed by a combination of speeds, maximal efforts and few repetitions.
 - **Slow-twitch fibers** respond to submaximal effort and endurance bouts that include long term low intensity. Therefore, these fibers are stressed more with submaximal effort and several repetitions.
- **Decreased joint compressive forces at faster speeds** - According to Bernoulli's Principle, the faster the movement of a surface (articular surface) over a fluid (synovial fluid), the less the surface pressure will be. Isokinetics allows the clinician to exercise patients at high speeds which decrease compressive forces on a joint.

- **Physiological overflow of strength** - Research indicates that exercising at a particular speed increases strength not only at that speed, but also at lower (and possibly higher) speeds.
- **Virtual elimination of ballistic movement** - Newton's first law of motion stated that a body continues in its state of rest or unified motion unless it is acted upon by an outside force. With isotonic exercise, the constant resistance of the weight adds to the inertial force of a moving body segment. With isokinetics, inertial forces are reduced because the resistance produced by the machine stops when the subject stops producing force.

The benefits discussed above apply to all uses of isokinetics for testing and rehabilitation. In addition, CSMI has included several features in its isokinetic equipment to ensure safety, comfort and valid results:

- **Correct alignment of the axis of rotation** - The CSMI TEF Modular Component allows the clinician to precisely align the machine's axis of rotation with the patient's anatomical axis of rotation. The body is not allowed to shift off axis or seek different angles throughout the range of motion.
- **Secure stabilization of non-moving body parts** - In addition to providing safety, stabilization prevents extraneous motion that might affect the reliability of test results.
- **Range of motion limitation** - The TEF Modular Component utilizes the computer controlled range-limiting and the secondary mechanical range-limiting of the NORM System dynamometer that allow the clinician to keep the patient within a specific range of motion.
- **Reproducible measurements** - In CSMI isokinetic testing, a patient's force output is displayed as a curve that clearly illustrates torque produced at each point in the range of motion.

By examining the shape of the curve, the clinician can locate problem areas that may be due to pain, fatigue, muscular weakness, mechanical dysfunction or pathology. Normal changes due to biomechanical leverage and muscular length/tension changes are also evident.

When force and torque measurements are used to make clinical assessments, the reliability of the information is crucial. CSMI isokinetic testing include features such as gravity correction and calibration of both the TEF Modular Component and the NORM System dynamometer to ensure the most reliable results.

Use of Isokinetics for Spinal Rehabilitation

Many studies using various equipment and procedures to measure trunk strength in normal subjects and in patients with low-back pain have been documented. Results from these laboratory studies have been valuable from an educational and developmental standpoint. Several of these studies are listed at the back of this section for reference. New studies are continually being conducted and the reader is encouraged to examine their findings as the reports are published.

Clinical Effectiveness of Isokinetics in Low-Back Pain Treatment

Research has been conducted that demonstrates the effectiveness of clinical treatment for chronic low-back pain and in the return of such patients to a productive lifestyle. One such study shows the importance of using functional, objective capacity measurements (including spine and hip ROM, isokinetic trunk flexion/extension strength, cardiovascular fitness & lifting strength) to guide the treatment of chronic back-pain patients. In this study, functional restoration treatment consisted of restoring the spinal and hip ROM, trunk strengthening utilizing isokinetics, and cardiovascular training. The treatment group showed objective improvement in these measures of function from the onset of the treatment. Only 14% of those in the treatment group were not working or involved in retraining after 10 weeks versus 55% of the comparison group and 80% of drop outs. Additionally, 33% of the drop-out group had further surgeries as compared with only 7% of the treatment group and 6% for the comparison group. Only 29% of the treatment group sought further outside medical care (other than the referring physician) while 56% of the comparison group and 67% of the drop-out group did. As shown by this study, individuals who were treated using the functional restoration approach, which included isokinetic trunk strengthening, had a high success rate.

In another study a five year retrospective analysis of the success of different rehabilitation approaches was documented. For this study, 100 subjects with chronic low-back pain underwent an eight week treatment program of either 1) modalities, 2) back school, 3) clinical exercise (which included isotonic) or 4) integrated (including isotonic & isokinetic.) The only difference between the clinical exercise program and integrated treatment program was the addition of CSMI back systems training in the integrated program. Initial results at the end of the treatment phase showed that the back school, clinical exercise and integrated program subjects had a reduction in low-back pain and were able to return to work, but only the integrated program group remained continued to work after five years. 82% of the integrated group continued to work versus 52% of the clinical exercise, 45% of the back school, and 8% of the modalities. Furthermore, only 6% of the integrated group had to seek further medical help versus 64% of the clinical exercise, 70% of the back school and 95% of the modalities groups. From this study it can be concluding that an integrated approach to low-back rehabilitation that includes isokinetic training is highly effective.

Population Trends of Trunk Strength

In the analysis of trunk strength data obtained from isokinetic trunk extension/flexion testing of both normal and chronic low-back pain subjects, several trends of each population become evident.

In the normal population, males have been shown to produce greater torque than females. With normal subjects, there was a slight force decrement as test speeds increased, this was more notable in the extensors than the flexors. Trunk extensor strength was observed to be greater than trunk flexor strength. (Some studies have shown that trunk flexor strength exceeds trunk extensor strength at speeds greater than 90 deg/sec.)

Analysis of isokinetic trunk flexion/extension testing data of the chronic pain population shows a reduced torque to body weight ratio as compared to the normal population. For these subjects as for the normal population, there was a force decrement as test speeds increased but also evident, is a striking torque drop off at the higher speeds (greater than 120 deg/sec.) This is most evident during trunk extension and is not seen in the normal population. The chronic pain population also demonstrates an inverse flexion/extension ratio, with the flexors being dominant at all speeds leading one to conclude that the extensors are more affected than the flexors by chronic pain. These trends are observed in both male and female chronic low-back pain patients.

Design Considerations

CSMI adopted the standing position for trunk flexion/extension testing after considering the results of trials using the prone/supine and seated positions. Among the many advantages it provides, this position:

- Maintains the normal orientation of the spinal curves, such as lumbar lordosis.
- Reflects functional vertebral body positioning.
- Simulates the way muscle groups act together in normal functional activities. This position allows a combined action by the abdominals, rectus femoris and the iliopsoas groups in flexion and gluteals and hamstring muscle group in extension.
- Allows the use of proper stabilization to eliminate extraneous or uncontrolled movements. This ensures reliable, reproducible results.
- Results in lower intradiscal pressures than in the sitting position.

CONTRAINDICATIONS

Contraindications for Isokinetic Sessions

Prior to Isokinetic testing or rehab sessions on the CSMI System, all patients should undergo a comprehensive subjective and objective examination.

Following is a listing of absolute and relative contraindications:

Absolute Contraindications

- Soft tissue healing constraints
- Severe pain
- Extremely limited range of motion
- Severe joint effusion
- Unstable joint

- Acute strain (musculo-tendinous unit)

Relative Contraindications

- Pain
- Limited range of motion
- Effusion or synovitis
- Chronic third degree sprain
- Subacute sprain
- Pregnancy (Discuss with patient's obstetrician)

For patients with relative contraindications, it may still be possible to institute some testing. Begin at a medium speed and increase to faster, then slower, testing speeds. It is also sometimes possible to test from fast to slow speeds.

For patients with neurological problems resulting in abnormal muscle tone (spasticity or flaccidity), testing may not provide an accurate measurement of muscle strength. Spasticity may be increased with medium or high speed testing or exercise. Patients with flaccid musculature will not strengthen the involved musculature with exercise unless those muscles become reinnervated.

Indications/Contraindications for Back Testing Sessions

Indications

The traditional rationale for prescribing therapeutic exercise also holds true for back testing using the TEF Modular Component. They include:

- Suspected weakness, deconditioning, or imbalance of trunk musculature.
- Overall deconditioning
- Long term combination lower extremity and trunk dysfunction.
- Unresolving musculoskeletal symptoms.

Contraindications

Contraindications to use of the CSMI TEF Modular Component are considered as relative vs. absolute. Those that are relative should be considered in the context of other subjective and objective findings.

Contraindications may be related directly to spinal pathology, other joint syndromes, cardiovascular limitations and/or other disease processes. These are outlined on the following pages. In evaluating any of these factors, the clinician's judgment is of paramount importance.

Absolute Contraindications

- Acute disc pathology.

Relative Contraindications

Relative contraindications due to **spinal pathology** include:

- Acute back pain. Example: Back pain that prevents proper execution of testing movements or increases with resistive movements.
- Neurologic signs. Examples: Weakness, tingling/numbness, decreased or absent reflexes.
- Peripheralizing pain. Examples: Pain into buttock or lower extremity following nerve root distribution.
- Trunk range of motion less than 45°. Example: Patient lacking hip and lumbar motion allowing for 45° total motion.
- Recent back surgery. The type of surgery and nature of the patient's response will dictate the action taken by the clinician. Examples: At the original testing sites, surgical patients were put on the units as early as two months post-surgery and routinely by six months post-surgery.
- Recent chemonucleolysis. Examples: At the original testing sites, chemonucleolysis patients were put on the TEF Modular Component as early as six weeks and routinely by three months.
- Osteoporosis. More common in women over the age of 45 years.
- Spondylolisthesis. Degree of slippage and alteration of symptoms must be considered.
- Spinal tumors. ***Close monitor by M.D. is advised.***
- Sacroiliac joint problems. Hypermobility problems may be irritated or malalignments accentuated.
- Inflammatory diseases. Examples: Rheumatoid arthritis or ankylosing spondylitis. ***Note: If patient is experiencing a flare-up of symptoms, contraindication is absolute.***

Other musculoskeletal considerations include:

- Patellofemoral syndrome - relative contraindication due to the flexed knee standing position (which may aggravate this condition) employed on the TEF Modular Component.
- Neck and upper thoracic problems - relative contraindication due to the overflow of force to these areas which may occur with maximal efforts.

- Heart, lung and vascular responses must be considered because of the intensity of the aerobic activity generated by maximal efforts on the units. Relative contraindications due to these responses include:
- Resting blood pressure higher than 160/100.
- Resting pulse rate higher than 100 BPM.
- Recent myocardial infraction. Close monitor by M.D. is advised.
- Active chest disease. Close monitor by M.D. is advised.
- History of high blood pressure.
- History of cardiovascular accidents.
- History of seizure activity.

Other considerations include:

- Pregnancy - The effects of isokinetic trunk testing on pregnancy are unknown at this time. While the advanced stages present obvious mechanical and stabilization difficulties, the early stages of pregnancy also warrant caution. ***Until more scientific evidence is available, trunk testing is not advised at any stage of pregnancy.***
- Recent surgery - particularly eye surgery.
- Medication side effects - masked symptoms or impaired patient judgment due to medication the patient is taking.
- Other neurologic pathology. Examples: Multiple sclerosis, muscular dystrophy, hemiplegia, etc.
- Impaired peripheral circulation - the lower extremity stabilization for the TEF Modular Component could compromise blood flow.
- Recent illness such as a cold or flu which may cause general weakness.

DESCRIBING JOINT POSITION IN THE RANGE OF MOTION

When describing movement patterns in detail, it is sometimes useful to specify a plane in which movement occurs. The "Planes of Motion" diagram below details the accepted terminology. Movement patterns that transect these planes are termed global patterns.

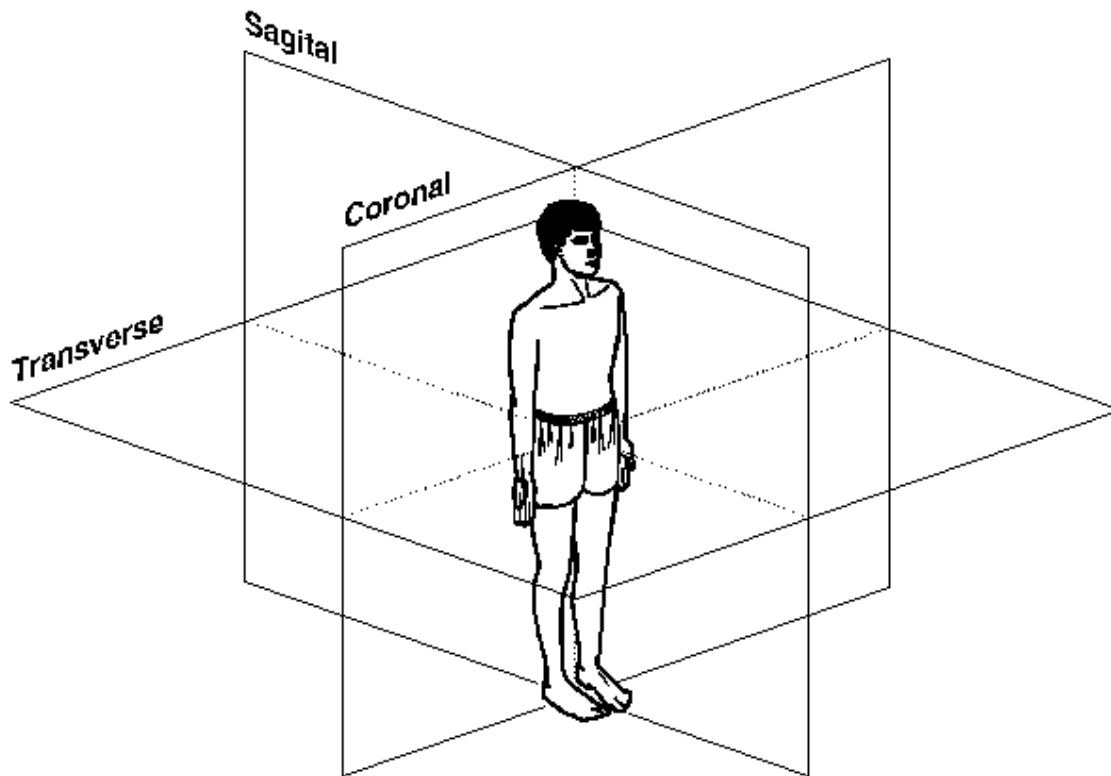

Figure 1-1. Planes of Motion

Each standard set-up pattern is accompanied by an illustration showing the recommended joint range of motion terminology for that pattern. Also shown, where applicable, are the "normal" end points of active range of motion as established by the American Academy of Orthopedic Surgeons Committee on Joint Motion. Alternatively, the range of motion of the uninvolved limb is considered to be an acceptable "norm" for evaluation purposes. The use of a goniometer or CSMI EDI 320 is recommended when maximum accuracy is required in range of motion measurements.

Regardless of the direction of movement or muscle group being tested, the joint position/angle at which any measurement is taken must always be described in a consistent fashion and the test speed stated in degrees/sec. Without limb velocity, measurements of torque provide only limited data on true neuromuscular capability.

DETERMINING TEST SPEEDS (HIGHLY ACTIVE VS TYPICAL ORTHOPEDIC PATIENTS)

Test speeds for each patient should be selected based on extent of injury and the particular activities to which the patient will be returning after rehabilitation is completed.

There may be large variations in test speeds between patients. Athletes, for instance, generally require much faster test speeds than non-athletic patients. (See Suggested CSMI Test Speeds Chart.) There is also a large sector of the population that falls between the athlete and typical orthopedic patient. This group may require testing speeds between the suggested parameters.

Many clinicians administer isokinetic test and rehab sessions over a velocity spectrum in which slow, intermediate and high-speed repetitions are performed. This allows a wide range of data to be collected and examined. The slow speed test provides a good indication of the patient's ability to withstand compressive forces. It also produces the best interpretation of torque curve shape. The curve's shape can then be examined by the clinician for possible indications of pain, weakness, etc. This testing speed provides the best information for peak torque/body weight and agonist/antagonist ratios.

The importance of intermediate and high-speed testing and rehab sessions lies in their ability to provide a more accurate measure of each muscle group's energy producing capability. It has been demonstrated that testing at high speeds will cause patients to produce lower peak torque and work rates but higher average power. Thus, intermediate and high-speed testing provide a better indication of muscular capability at functional speeds. Additionally, high-speed testing is suggested for determining endurance ratios since these speeds are closer to those of functional activity.

SUGGESTED TEST SPEEDS			
		HIGH SPEED TORQUE & ENDURANCE TESTS*	
TESTING/EXERCISE PATTERN	SLOW SPEED TORQUE CURVE TESTS	TYPICAL Patient	HIGHLY ACTIVE patient
SHOULDER Extension/Flexion Abduction/Adduction Int/Ext Rotation All other Patterns	60 deg/sec	180 deg/sec	240 or 300 deg/sec
ELBOW Extension/Flexion	60 deg/sec	180 deg/sec	240 deg/sec
FOREARM Pronation/Supination	30 or 60 deg/sec	120 deg/sec	180 deg/sec
WRIST Radial/Ulnar Deviation Extension/Flexion	30 or 60 deg/sec	120 deg/sec	180 deg/sec
HIP Abduction/Adduction Extension Flexion Int/Ext Rotation	30 or 60 deg/sec	120 deg/sec	150 deg/sec
KNEE Extension /Flexion	60 deg/sec	180 deg/sec	240 or 300 deg/sec
Tibial Int/Ext Rotation	30 or 60 deg/sec	120 deg/sec	180 deg/sec
ANKLE Plantar/Dorsiflexion Inversion/Eversion	30 or 60 deg/sec	120 deg/sec	180 deg/sec

*Some patients may not be able to achieve the suggested high speeds. A possible alternative in these cases is to determine a speed at which the patient is comfortable and then increase the test speed one setting at a time (i.e., 60, 75, 90). Have the patient perform two or three maximum pain-free repetitions at each speed. The object is to find the highest speed at which the patient can produce torque, and to record the patient's torque capability over the range of speeds of which he/she is capable. These records can then be used for comparison later in the rehabilitation program.

RATIONALE FOR STANDARDIZED RULES AND PROTOCOLS

Standard Rules and Protocols

In addition to the standard patterns included with the CSMI NORM System, a number of other patterns have been described in literature, seminars and meeting presentations. New testing and rehabilitation methods and capabilities are constantly being investigated and developed.

To ensure consistency of data gathered on CSMI NORM Systems, it is recommended that clinicians standardize the entire testing procedure including giving instructions to the patient. Considerable research has shown CSMI tests to have excellent intra-test and inter-test reproducibility and reliability. This is so even when patients are given minimal instructions and as few as three trial repetitions. Providing each patient with a full set of instructions and testing within the confines of a standardized procedure will help to ensure that chances of recording inaccurate data due to extraneous or confounding variables are minimized.

In order to use data generated from the TEF Modular Component for research or medicolegal purposes, the highest level of reliability must be sustained. Since this does not require extra steps, it is suggested that all test data be collected following certain specific guidelines. This will ensure the best clinical result and will allow the clinician to be prepared for any eventuality regarding later use of test data. The use of a research-proven test protocol may be helpful for data interpretation and the fine tuning of test techniques.

Listed below are some ideas on making the CSMI NORM session procedure as uniform as possible.

- 1. For extremity testing, always test the uninvolved side first, through the same ROM as the involved side.**

Testing the uninvolved side first is essential for accurate data interpretation because the computer bases all bilateral comparison calculations on the basis of uninvolved versus involved limb data.

Testing the uninvolved side first allows the patient to become familiar with the movement pattern, test requirements and totally accommodating resistance of isokinetic testing with minimal apprehension. For accurate comparison of work, power and endurance, it is essential that both sides be tested through the same range of motion even if the uninvolved range is much greater. Measurements of these parameters are dependent upon the range traveled; comparisons can only be made when the ranges are equivalent.

- 2. Provide a simple but thorough and consistent explanation of the dynamic requirements of the isokinetic test.**

For example: “The CSMI NORM System will not resist you until you match the preselected speed. You must push and pull as hard and as fast as you can throughout the entire range of motion on every rep.”

Add a statement like the following: “If you feel pain during the test, reduce your effort and the machine will decrease its resistance. If you stop, the machine will stop. And we will be able to tell if you gave your best effort throughout the range of motion on each rep.”

- 3. Three to five submaximal and one maximal repetition should be performed at each test speed immediately prior to the test.**

Warm-up repetitions should start with minimal effort and build in intensity so that the last repetition is at a maximum level.

- 4. Consistent and firm verbal encouragement should be given throughout each set of the testing bout.**

Most patients will reduce force output substantially or stop the pattern completely if pain is encountered. The CSMI NORM System will instantly accommodate to any change so that the movement can continue at a pain-free level during isokinetic testing.

Some highly motivated patients may attempt to maintain force output even through significantly painful portions of joint ROM. It is the clinician's responsibility to observe, judge and appropriately instruct these patients. The muscular pain of fatigue (lactic acid) resulting from primarily anaerobic power-endurance tests must be differentiated from joint and connective tissue pain caused by existing pathology or injury.

- 5. During extremity testing, particularly during initial evaluations, re-test the involved side to make sure maximum efforts are reproduced.**

After getting the "feel" of how the system works during trial repetitions, the majority of patients give their best effort on tests of the involved side. Still, especially for an initial evaluation, it is a good idea to re-test the involved side or repeat a speed within the test protocol to help in evaluating reproducibility of effort. Consistency of torque curve shape provides information about the patient's consistency of performance. If the test results are in doubt, have the patient return for re-testing the following day.

Other helpful procedures for evaluating reproducibility of effort include repeating a speed within a test protocol, and bringing a patient back to repeat testing at approximately the same time within a one or two-day period.

Additionally the clinician should:

- Record the patient's set-up positioning and stabilization at the entries provided on the Patient Set-up Form.

- Provide brief low intensity stretching and low intensity, submaximal work of muscle groups to be tested. This warm-up may often be done on the test device itself.
- With the exception of the work recovery capability test, sufficient rest should be given between sets to allow true maximum force production. Suggested rest periods have been incorporated into the software protocols for back testing.

SETTING REHABILITATION GOALS

Since isokinetic measurements are the best method by which many parameters of human performance can be quantified, some means of rating an individual's performance relative to a comparable population is necessary. One method of establishing rehabilitation goals frequently used by clinicians is to compare normative studies of peak torque/body weight ratio to test or exercise results. This is especially true of knee, shoulder and trunk rehabilitation. To be most useful, normative values need to be specific to occupational and/or sports and leisure activities. This will take into account the actual functional demands likely to be encountered by the individual. Specific studies of narrowly defined populations are especially helpful in this regard.

In the absence of specific normative values, measurements of an individual's contralateral or uninvolved side may provide valuable information about that particular individual's normal capability. These measurements are generally suitable rehabilitation goals for the involved side; however, clinical experience and an understanding of the patient's activities are also important in setting rehabilitation goals. Before making bilateral comparisons, it is important to establish that the uninvolved side is "normal." If it is not, bilateral rehabilitation may be indicated to bring the uninvolved side up to normal performance levels even while rehabilitating the involved side. The establishment of rehabilitation goals via an uninvolved side which is incapable of producing adequate torque, will not allow for establishment of proper performance levels for the involved side.

Once the primary stabilizers (i.e., cartilage, ligaments) have healed sufficiently, functional rehabilitation goals can be established. These should assume a logical progression beginning with restricted motion or submaximal efforts and progressing to higher velocities and force outputs. Some clinicians require that specific peak torque to body weight ratios be achieved before allowing the patient to perform activities such as running. Others look at sport activities and age group in relation to peak torque/body weight ratio. With extensive ligamentous or joint damage, more conservative goals may be needed based on joint stability.

The clinician must always monitor the effects of the exercise prescribed. In the early stages of rehabilitation on the CSMI NORM System, it may be necessary to restrict activities to submaximal efforts, restricted range of motion, low numbers of repetitions and/or intermediate exercise speeds. If this program is well tolerated by the patient, repetitions, speeds and effort can be gradually increased and the joint further stressed by increasing range of motion. Signs of joint irritation such as temperature increase and edema should always be monitored.

For patients with ACL laxity or surgery, use of the Johnson Anti-Shear accessory may prove beneficial (see CSMI pamphlet, "Controlling Shear During Knee Extension\Flexion, A Handbook For Using The Johnson Anti-Shear Accessory.") When indicated, the CSMI NORM System's graphic torque display should be used to help patients stay within prescribed torque output levels.

Initial Isokinetic Test

When choosing the type of initial isokinetic test to be performed, the clinician has several options. The type of test to be used should be determined by the results of the subjective/objective examination. For patients with no contraindications, a complete test may be warranted. For patients with limitations, a modified protocol may be most beneficial. In cases of absolute contraindication or severe limitations, the clinician may want to consider deferring the test until a later date.

Patients should not be permanently excluded because of initial findings. They may later benefit from complete or modified use of the CSMI NORM System and/or TEF Modular Component.

The types of isokinetic tests that can be performed are outlined below. These categories also apply to rehabilitation programs:

- *Complete:* The test is conducted using either a facility protocols or one that was specifically created for the person being tested. The patient's FULL range of motion is tested and he/she is encourage to exert maximum effort throughout the test.
- *Modified:* The test is performed according to the limitations of the patient. For example, modifications can include setting the range of motion stops to accommodate for difficult areas in the range; limiting the number of repetitions and/or speeds; and instructing the patient to perform submaximal efforts in the direction that causes pain.
- *Deferred:* Testing or exercise is not immediately performed due to contraindications. Use of the back testing and rehabilitation systems is then predicated upon re-evaluation of patient's signs and symptoms. As the patient's condition improves, a complete or modified program may be conducted. (i.e., A patient with an acutely injured disc is contraindicated for isokinetic testing or exercise. As re-evaluation indicates a decrease in signs and symptoms, the patient can be geared toward complete or modified back testing and rehabilitation.)

Factors to consider during any initial isokinetic test include:

- Muscle group weakness.
- Patient's ability to generate torque at isometric, slow and/or fast speeds.
- Shape of curves, indicating either general weakness or a specific pain/instability deficit.
- Patient's cardiovascular response to testing.

Any isokinetic test (including the initial test) or exercise should include the following procedures:

Warm-Up

- Before starting the test or exercise, the patient should engage in a short cardiovascular warm-up to raise muscle temperature (e.g. using a UBE or Fitron.)

- Prior to the actual session, the patient should actively stretch the muscles which will be involved in the test.
- Prior to each speed set, the patient should perform submaximal and maximal effort warm-ups on the unit.

Record-Keeping

Throughout the program, the clinician should consistently record:

- Pertinent patient information on pain, progress, range of motion, endurance and other factors.
- Blood pressure and pulse before and after each session.
- Stabilization and set-up information.
- Body weight and, if possible, percent fat changes.
- Other pertinent data to insure accurate records and consistent test administration.

Precautions

Subjects should be monitored closely for signs of distress during any testing or exercise session. The clinician should pay close attention to the patient's:

- Vital Signs - Monitor blood pressure and heart rate, before and after the session.
- Color - in response to exertion.
- Quality of movement.
- Degree of motivation and effort.
- Pain rating.

Program Parameters

All CSMI test and rehabilitation protocols, whether complete or modified, consist of the following parameters:

- Speeds - measured in deg/sec. Speed is independently assigned to each direction of movement.
- Number of repetitions.
- Duration of the test or exercise session - number of sets.
- Sequence of sets - slow to fast speeds, etc.
- Range of motion.

- Intensity of contraction - submaximal versus maximal effort.
- Length and number of rest periods.
- Frequency of sessions - how many per week.

At the start of the test or rehabilitation program, the clinician determines the settings and values for these parameters (i.e., how many deg/sec, how many sessions per week, etc.) based on the results of the initial isokinetic test. As treatment progresses, the parameters can be changed.

Discharge Parameters

A formal re-test should be conducted at regular intervals and prior to discharge. The following factors may indicate that a patient is ready to be discharged:

- The patient is able to achieve the desired active and passive range of motion.
- The patient achieves desired values for specific isokinetic parameters (i.e., peak torque, total work, endurance, etc.)
- The patient improves with regard to other physical factors as determined by the clinician.

Possible Side Effects of Trunk Testing

Clinicians at the original test sites have reported the following possible side effects:

- Skin irritation caused by rough texture of patient's clothing.
- Post-exercise muscle soreness related to isometric and eccentric bouts. However, few complaints were reported with concentric isokinetic protocols. The clinician may wish to avoid extensive use of isometrics and eccentrics to reduce muscle soreness.
- Patient complaints of soreness following reciprocal work on the back testing unit (reported at one site.) Non-reciprocal patterns were utilized by this facility during initial testing in an effort to decrease soreness complaints. Reciprocal testing and exercise was consistently used by the other test sites without complaint.
- Fainting resulting from inadequate breathing or lack of nourishment on the day of the test or rehabilitation session. The clinician should remind the patient to breath properly and explain the importance of eating the day of, but not immediately prior to, the session.
- Hysterical reaction. This manifests itself as an irrational response to being on the unit, including an intense felling of fear, anxiety or claustrophobia.
- Occasional incidence of transient back pain requiring termination of testing.

CLINICAL APPLICATIONS OF RANGE LIMITING

The Range-Limiting System allows precise, reproducible control of joint range of motion in keeping with specific rehabilitation goals and patient limitations.

Specific Injuries, Pathologies and Postsurgical Considerations

Range limiting is particularly important in the postsurgical rehabilitation of many common repair and reconstructive procedures for the knee and shoulder. It may also be used to prevent aggravating existing conditions or over stressing recent sprains or strains during exercise rehabilitation. Additionally, range limiting is often useful in the treatment of numerous diagnosed or suspected joint injuries and pathologies including:

- Chondromalacia patella
- Anterior cruciate ligament involvement
- Posterior cruciate ligament involvement
- Knee or elbow hyperextension
- Chronic shoulder subluxation
- Shoulder dislocation
- Joint/soft tissue impingement syndromes
- Bursitis, synovitis and capsulitis
- Any painful arc symptomatology
- Patellofemoral pain syndrome
- Ankle sprain or ligament involvement

Equalizing Range For Bilateral Comparison

The integral range-limiting system can be used to place identical range limits on both limbs when performing a bilateral comparison. This is particularly useful when the range of the involved side must be limited and precise comparison of work and power capability is desired. This is not generally recommended when neither side requires range limiting because active range of motion limits should be considered as part of the bilateral comparison.

Avoiding Painful Arc

The range of motion stops can be adjusted to allow protected exercise in short arcs first on one side then on the other side of a painful mid-range. The stops can also be adjusted to prevent excursion into extremes of the range of motion where impingements are most likely to occur, or to establish short arc exercise at a particular point in the range of motion.

Isometric Hold At The End Of Range Of Motion

During exercise, range limiting can be used to provide an isometric hold at either or both ends of the desired active range of motion. For example, when exercising at slow to moderate speeds, it may be desired for the patient to perform a six second isometric contraction in terminal knee extension before reversing direction.

Important Safety Information

It is important to note that limiting range of motion does not eliminate other possible contraindications to testing or exercise. In addition to controlling the range of motion, it is necessary to have the patient exercise at appropriate speeds and force levels. Some types of injuries and surgical procedures require that joint motion be limited to a specific range for some part of the rehabilitation program to avoid further injury or re-injury. It is the clinician's responsibility to identify these risks and provide adequate safeguards. Limiting the range of motion may be necessary. Careful initial evaluation and supervision will usually uncover any necessary precautions or program modifications.

When range limits are set well before musculoskeletal limits, deceleration of the moving limb segment by the antagonist muscle group and the opposing passive structures occurs differently than in regular full range isokinetic exercise. Because the resistance mechanism of the dynamometer absorbs all applied exercise forces, however, the actual impulse load when contacting the stop is quite small.

In the case of knee exercise (using the standard shin pad) for example, the entire moving limb segment is stopped at its center of gravity, therefore, no significant impulse load or distracting force reaches the knee joint. In shoulder exercise, however, the point of application of force is distant from the limb segment's center of gravity. Consequently, the proximal shoulder does see some distracting force when the limb is stopped quickly. For this reason, CSMI recommends slow to moderate speeds and controlled submaximal exercise during the early stages of shoulder rehabilitation, whether or not range limiting is used.

CORRECT LENGTH ADJUSTMENT OF INPUT ACCESSORIES

For gathering reliable data, selecting the correct length adjustment for input accessories can be as important as aligning the axis of rotation. Incorrect length adjustment will not allow a smooth, comfortable movement through the full range of motion, and may interfere with joint stabilization. Note that for tibial rotation and wrist or ankle patterns, axis alignment is primarily controlled by the length adjustment of input accessories.

Before proceeding with any test or exercise pattern, have the patient perform a few trial repetitions at each test speed to check positioning, accessory length, and patient's understanding of effort required. Errors not large enough to affect smoothness and comfort of movement or restrict active range of motion will probably not significantly affect torque production.

Significant Error Indications For Input Accessory Length Adjustments

Significant error in length adjustment and/or axis alignment is indicated by one or more of the following:

1. Patient's limb feels stretched or compressed throughout entire range of motion.
 - *Length adjustment is too long or too short.*
2. Patient's limb feels stretched at one extreme of range and compressed at the other extreme.
 - *Axis alignment is off; patient must be moved slightly towards direction in which limb feels stretched or a little closer to the dynamometer.*
3. Patient's limb feels compressed or stretched in mid-range, better at extremes.
 - *Axis alignment is off; move patient toward stretched position or away from compressed position.*
4. Limb segment proximal to joint being tested moves up/down or side to side as patient moves through range of motion.
 - *Axis alignment is off and/or stabilization is insufficient. For ankle and wrist patterns, length adjustment primarily controls axis alignment. Try longer or shorter adjustments until proximal movement stops. For other patterns, double-check appropriate straps and indications above. Apply manual stabilization of body and proximal limb segment if required.*

Input Length and Leverage Advantages

While it is obvious that a longer input arm length gives the patient a greater leverage advantage on the dynamometer, this advantage is discounted because the patient's limb works as a lever arm also. As the input arm is made longer, the point at which resistance is applied to the

patient's limb is placed farther from the joint. This puts the patient's joint at a greater leverage disadvantage. Because the distances from the joint's axis of rotation and the dynamometer's input shaft to the point of resistance application are the same, any leverage advantage on the dynamometer is negated by an exactly equal leverage disadvantage of the patient's limb. Furthermore, CSMI measurements of torque are made at the axis of rotation of both the tested joint and the dynamometer. This is the most accurate way of measuring torque.

Understanding the limb-length/joint-leverage relationship makes it clear that isolated-joint measurements or comparisons should not be made based on pounds of force produced or weight lifted. Unless the distance from the joint axis to the point of application of resistance is known, a measurement in weight or pounds can be highly inaccurate. Torque measurements, on the other hand, are independent of this variable. To eliminate other possible variables, standardized adjustment procedures are recommended in the general information section for each joint.

Biomechanically, joints and their muscle groups are torque producing mechanisms. Properly made torque measurements are accurate, reproducible and directly comparable from joint to joint and individual to individual regardless of limb lengths and body sizes.

EFFECT OF GRAVITY (on Testing Procedures and Results)

Gravity and the NORM

The CSMI System's positioning and input accessories are designed to minimize the effect of gravity on reciprocal muscle groups, allowing most patients to be safely tested or exercised on this unit. Generally, patients who cannot move against gravity are not tested with this device.

In almost every pattern performed on the unit, one muscle group's action is assisted by gravity while the reciprocal muscle group must overcome the effect of gravity. This is generally disregarded in clinical evaluations and test comparisons, however, as the effect of gravity is totally reproducible. Furthermore, because gravity is an integral component of all functional movement, it may not be necessary or desirable to correct for its effect under most clinical conditions.

When comparing CSMI System data (torque at specific joint angles) to research applications which require absolute numbers, the effect of gravity must be eliminated from measured values. For such instances, the CSMI computer can be programmed to automatically correct for the effect of gravity at every point in the range of motion and for all work, torque and power measurements.

When To Correct For Gravity

Because gravity is an integral component of all functional movement, it may not be necessary or desirable to correct for its effect. Under the following conditions, however, gravity correction should be performed:

When Comparing Test Results To Research Data

When making comparisons to specific research data, it is necessary to determine if the data has been corrected for gravity. If so, your test results must also be corrected for gravity before accurate comparisons can be made.

When Evaluating High Speed Tests

As speed increases, torque decreases but gravity stays the same. Thus, the effect of gravity as a percent of measured force output varies greatly. It is less significant with strong patients and slow speeds where forces are likely to be greater, but it may be 50% or more of measured force with very weak or fatigued patients, or at fast test speeds. Muscle groups working against gravity would therefore be apparently weaker, and muscle groups working with gravity would appear to be stronger. Eliminating the effect of gravity will give a more accurate picture of each muscle group's actual torque capability.

When Evaluating Agonist/Antagonist Ratios

The proportional effect of gravity may distort agonist/antagonist ratios to a considerable degree. This is especially significant when considered over increasing test speeds. To clarify this point, examine gravity's effect on quadricep/hamstrings ratios. (As speed is increased, uncorrected quadricep/hamstrings torque values will display an increase in ratio. When

corrected for gravity, hamstring torque production will always decrease as speed increases.) As speed increases, gravity becomes a greater proportion of total hamstring torque. At the same time, the negative effect of gravity also decreases as a proportion of total quadricep torque. This creates a change in ratio between these reciprocal muscle groups. In effect, the hamstrings appear to be stronger relative to the quadriceps at high speeds than they are at slow speeds. This change is less significant when torque values are corrected for gravity.

When Performing Endurance Tests

When performing endurance tests, the muscle group being assisted by gravity may falsely appear to have better endurance than the reciprocal muscle group.

Variation In Weight Of Limb

A small variability in the weight of limbs may be unavoidable if the patient is unable to completely relax. Variations of + 1 ft. pound should be considered normal and insignificant to final test results. Variance in excess of + 2 ft. pounds may indicate the patient is not fully relaxed, is slightly spastic, or has excessive muscular stretch in that part of the ROM.

A difference in limb weight may also be noticed from side to side when one limb is greatly dominant or significantly atrophied. This can result in differences as high as 25% between left and right limbs.

CONSIDERATIONS FOR ECCENTRIC APPLICATIONS

Mechanical Considerations

It is well known that eccentric activity generates more tension in the muscle than concentric activity. However, based on many studies, the clinician must realize that the tension being generated is not exclusively due to the contractile elements producing the force. Research indicates much of the tension that is developed is actually due to the non-contractile tissue being pulled apart during an eccentric action. This creates more mechanical tension within the muscle.

The clinical implications of this research indicate that if the objective is to maximally elicit the contractile elements of the muscle, then it must be performed through a concentric action where only the contractile elements can be producing the tension. If the goal is to stimulate the contractile and non-contractile elements of the muscle, then eccentric activity must be used to focus on the non-contractile elements.

Delayed Onset Muscular Soreness (DOMS)

DOMS is defined as an unaccustomed muscle soreness occurring post muscular exertion. DOMS is known to occur after concentric and eccentric activity, yet most studies have investigated the reasons for DOMS post eccentric exercise. Several different theories have been suggested as to why DOMS occurs post eccentric exercise. Research has shown that DOMS has occurred to one degree or another in almost all eccentric studies. Most studies suggest that after eccentric exercise DOMS increases the first 24 hours, peaks from 48 to 72 hours (2 -3 days) and decreases by 120 hours (5 days). It is suggested that this time frame, as well as the post therapy activities, be considered when designing the frequency and duration of eccentric exercise programs.

Decrease in Strength Post Eccentric Exercise

Several research studies have suggested that following intense eccentric activity there is a significant decrease in muscle tension development and strength. Most studies suggest that this muscle weakness is noted immediately post eccentric exercise and may last up to one week. It is suggested that this also be considered when designing rehabilitation exercise programs and frequency of isokinetic testing.

ISOMETRIC APPLICATIONS

Isometrics and the NORM

While the vast majority of testing on CSMI System will involve isokinetics, there are times when it may be advantageous to test the patient isometrically. Before proceeding with any isometric tests, however, it is important for clinicians to note that there is a natural discrepancy between data gathered isometrically and isokinetically. As a result, studies of isokinetics cannot be compared to isometric test results for use as normative data. For bilateral comparisons, isometric data must be gathered from the same point in the range of motion for each side.

Isometric exercise can also be applied to the rehabilitation program. Such exercises are often prescribed on CSMI System when a patient cannot produce enough torque or does not have adequate range of motion to accelerate to a pre-set isokinetic speed. Indications for use of isometric exercise, in addition to advantages and disadvantages, are listed below.

Indications for isometric exercise include:

- Inability to produce adequate torque
- Joint with a painful arc
- Unstable joint
- Limited ROM
- Early stages of post-operative rehabilitation

Advantages of isometric exercise include:

- No joint movement, therefore isometrics can be used early in the rehabilitation program.
- A + or - 10 degree physiological overflow effect in ROM
- A positive increase in strength at angles exercised

Disadvantages of isometric exercise include:

- High joint compressive forces during maximal contractions
- No increase in endurance
- Must do multiple angle isometric exercises to strengthen through the full ROM
- Increased blood pressure

Beginning an Isometric Exercise Program

An isometric exercise program should be started with submaximal contractions and progressed to maximal contractions as tolerated. For maximum benefit, common instructions to the patient should include the following sequence:

- 2 second build-up
- 2 second hold
- 2 second release

It is important to note that maximal isometric contractions can produce high joint compressive forces and high blood pressure responses. Therefore, caution should be exercised in prescribing isometrics. Effort of contractions, when the patient is progressed from submaximal to maximal, should be comfortable and kept to a reasonable time frame (6 seconds or less). Special precautions should be taken with cardiac patients (i.e., monitoring heart rate and blood pressure). Clinicians should also instruct patients to continue to breath normally during contractions. As soon as patients develop the capacity to exercise isokinetically, they should. Isokinetic and isometric exercises can be combined in some movement patterns by instructing the patient to "hold and continue pushing" at the end of each movement.

Many isometric rehabilitation programs used today incorporate multiple angle isometrics. In this instance, isometrics are performed through the indicated ROM in which the patient can safely exercise. The patient is instructed to use isometrics based on the rule of tens (i.e., 10 second contraction, 10 second rest, 10 sets, 10 angles, etc.). Particular attention is paid to applying isometrics on each side of a "painful" deformation.

Using such a program it is possible, with the help of physiological overflow, to strengthen the patient's entire ROM.

As is the case with standard isometric exercise programs, a multiple angle isometric exercise program should begin with submaximal contractions and progress to maximum efforts as tolerated by the patient.

For the knee, the highest compressive forces occur at mid- range. Since these forces can be detrimental to the joint surface of the patellofemoral joint, isometric contractions should be performed at 0 - 15 degrees for both flexion and extension movements when strengthening of the mid-range is indicated. This will allow for physiological overflow with a greatly reduced risk of irritation or reinjury. The remaining range should be exercised at every 20 degrees of ROM. For other joints, isometric contractions are usually performed in the neutral position or every 20 degrees of ROM.

SECTION 2. MECHANICAL OVERVIEW

A basic overview of the CSMI NORM Testing & Rehabilitation System's mechanical components is provided within this section. All positioning scales and adjustment knobs and clamps are identified for easy reference. Minimum operating requirements are outlined as is the proper method for turning the system on and off.

Chair placement in relation to the CSMI NORM System dynamometer is discussed, along with the proper method of adjusting the chair's seat and back support. A general explanation is given for changing the dynamometer's position and for the proper method of installing the input adapters and adapter accessories on both the dynamometer and reclining chair. Dynamometer and chair placement, and a listing of the adapters and accessories used for specific testing and rehab patterns, can be found within **SECTION 3. PATTERN SELECTION AND SETUP**.

Patient stabilization and the use of mechanical range of motion stops for range limiting, a key to the operational safety of the CSMI NORM System, is explained in this chapter. For a detailed discussion of range limiting, refer to **SECTION 1. CLINICAL APSECTS**.

BASIC CONFIGURATION AND SPECIFICATIONS

Dynamometer

Low-Torque Servo Amplifier

Modes	Speeds/Secs	Torque
Concentric	500 deg/sec	500 ft. lbs. / 678 Nm
Eccentric	300 deg/sec	300 ft. lbs. / 678 Nm
CPM	5-150 deg/sec	300 ft. lbs. / 678 Nm
Isometrics		300 ft. lbs. / 678 Nm

High-Torque Servo Amplifier

Modes	Speeds/Secs	Torque
Concentric	500 deg/sec	500 ft. lbs. / 678 Nm
Eccentric	300 deg/sec	500 ft. lbs. / 678 Nm
CPM	5-150 deg/sec	500 ft. lbs. / 678 Nm
Isometrics		500 ft. lbs. / 678 Nm

Unit Footprint

- 4' x 7' (28 square feet)
- 1.2m x 2.1m (2.4 square meters)

Software

- Windows® Based software
- Integrated Networking capabilities
- English or Metric software
- Multiple languages available

Computer (Domestic Configuration)

- PC-Compatible Pentium
- Hard Drive
- CD-ROM Drive
- Color Monitor

- Color Printer

Electrical

- Input Voltage: 220 VAC (other voltages available)
- Input Frequency: 50/60 Hz
- Independent 20 AMP dedicated circuit REQUIRED
- System includes integral EMI/RFI and surge suppression
- International wiring standards



Figure 2-1 NORM System Overview

THE ELECTRONICS PANEL

The Electronics Panel affords the user access to the front panel of the HUMAC Interface and the computer. The HUMAC controls and monitors dynamometer speed, force and direction. An electrical signal from the dyna motor encoder provides the HUMAC Interface with dyna shaft position and direction information, while the torque board inside the dynamometer housing provides the HUMAC with torque, or resistance values encountered at the input shaft. This information is then provided to the computer and application software to provide visual feedback and data to the user for evaluation.

The HUMAC is always powered up with the NORM System and has no provisions for disconnecting it from its power supply. The visible front panel of the HUMAC has the outlet for the Comfort Switch and the USB connector.

The computer is an IBM-PC Compatible Pentium when purchased with the CSMI NORM System.

The Electronics Panel contains the following indicators and controls:

- Power Indicator - lights up when computer is receiving electrical power.
- H.D.D. - Hard Disk Drive Access light, lights up when disk is being accessed by system
- Reset Button - enables user to reboot (restart) computer without turning power off, and then on again.

Behind the access door in the lower right hand corner is the computer on-off switch. At the uppermost part of the computer are the drive bays where one or more floppy or CD-ROM drive components may be installed.

SYSTEM POWER-UP

Turn on the peripherals such as the printer, monitor and computer.

1. Turn on the main system switch. (located on the NORM side opposite the Electronics panel.)
2. Press the computer power button.
3. The system runs through its hardware and software checks; at their completion, the Microsoft Windows Desktop with the HUMAC icon is displayed.
4. Double click the HUMAC icon to start the HUMAC program.
5. The HUMAC Warm-up dialog box is displayed.
6. Complete the Warm-up procedure.

Note: Refer to 300830 HUMAC2014 Program Guide for further details on using the software.

MECHANICAL OVERVIEW

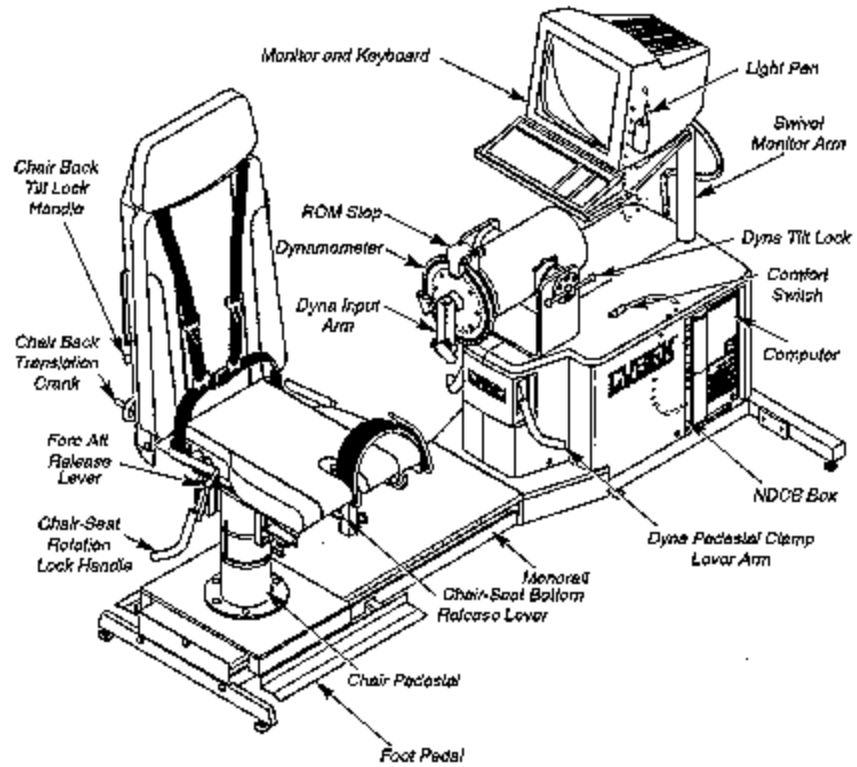

Figure 2-2 Major Mechanical Components

NORM SYSTEM PARTS AND COMPONENTS

Electronics Enclosure: The *Electronics Enclosure* houses the system electronics and the computer.

Comfort Switch: The *Comfort Switch* is handed to the patient at the start of a test or rehab session. If he/she should feel any discomfort during the session, pressing the switch will immediately abort the session and stop the machine.

Dynamometer: An integral part of the NORM System, the *Dynamometer* measures the torque produced by the patient. It provides controlled testing or exercise speeds from 0 to 500 deg/sec. and can withstand joint torques of up to 500 ft/lbs. The dynamometer's rotation, height and tilt can be changed to properly position it for the testing or rehab pattern being used. For all standard patterns, the Patient Set-Up Window displays "prompts" to help the clinician position the dynamometer and also provides a form to record the rotation, height and tilt scale values.

Range Limiting System: The *Range Limiting System* provides computer controlled range of motion and visible mechanical backup stops.

Monorail: The chair glides along the *Monorail* for easy patient placement proximal to the dynamometer. The Monorail Scale, located on both sides of the monorail, provides reproducible placement of the chair pedestal.

Reclining Chair: The *Reclining Chair* assures stability during testing or rehab sessions. Multiple adjustment angles allow patients to be set-up in sitting, prone or supine positions for extremity testing or rehab and provide the clinician with consistent, reproducible patient placement. The seat moves fore and aft and provides the appropriate stabilization of the torso, hips, waist, thighs and the contralateral limb.

Grab Bar: *Grab Bars* are strategically placed on the reclining chair's seat and back to provide anchor points for the thigh and torso stabilization belts, to provide "handles" to facilitate proper positioning of the system by the clinician, and to provide stabilization grips to the patient during the session.

Stabilization System: Consists of a seat belt, double shoulder belts, thigh stabilization belt, handle bars and grab bars, contralateral limb stabilizer for the knee, forearm stabilization V-pad, thigh stabilization pad and the reclining chair. The stabilization system helps prevent muscle substitutions while allowing the patient to be tested in a safe, comfortable and anatomically correct position.

Swivel Monitor Arm with Keyboard and Monitor: The *Swivel Monitor Arm* allows easy access to the *Keyboard and Monitor* from either side of the chair. The keyboard and monitor can be turned away from the patient during testing or positioned to face the patient during a rehab session to provide a motivational display.

Printer: A printer provides a hard copy record of the patient's test or rehab session data. A color printer can be purchased through CSMI or through a local computer hardware supplier. All printing is done through Windows.

Adapters and Accessories

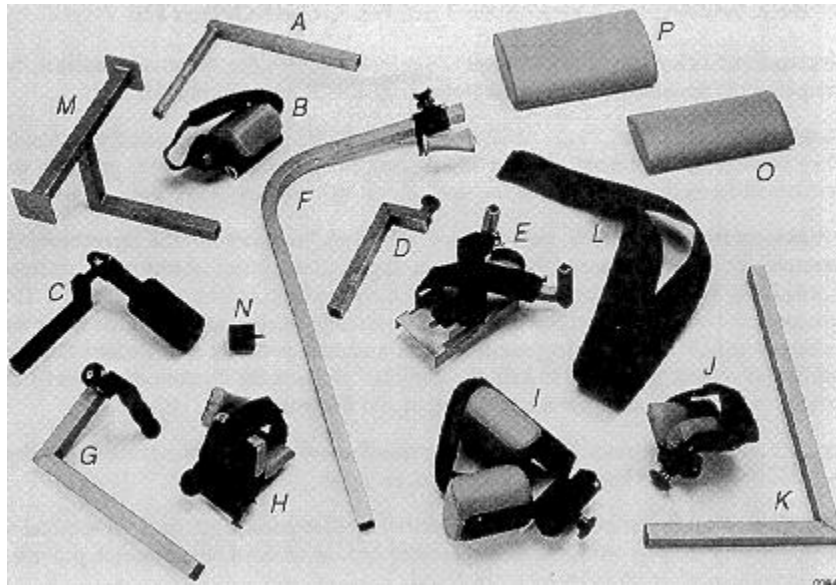

Figure 2-3 Adapter and Accessories

A	Knee/Hip Adapter	I	Thigh Stabilizer Pad
B	Knee/Hip Stabilizer Pad	J	Forearm Stabilizer V-Pad
C	Contralateral Limb Stabilizer	K	Thigh/Forearm Stabilizer Tube
D	Ankle Adapter	L	Torso Belt
E	Footplate	M	Footrest
F	Elbow/Shoulder Adapter	N	Counterbalance Weight (.8kg)
G	Wrist/Shoulder Adapter	O	Head Cushion
H	Elbow Stabilizer Pad	P	Lumbar Cushion

DYNAMOMETER POSITIONING

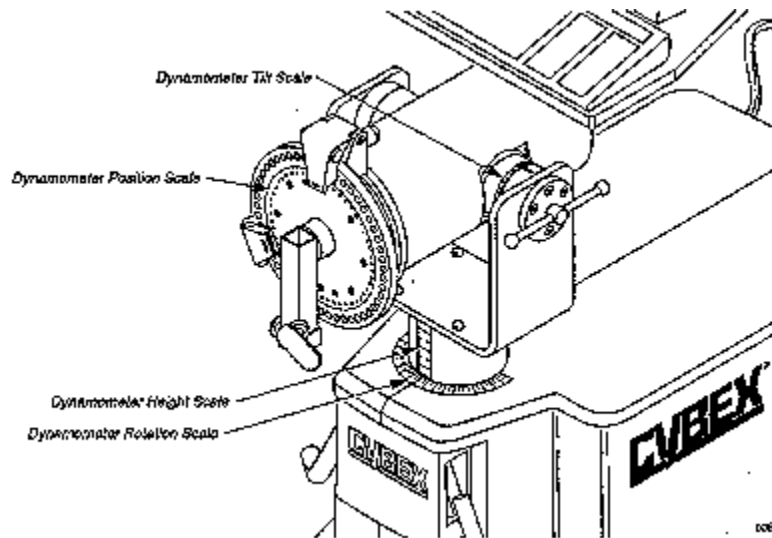

Figure 2-4 Dynamometer Scales

The dynamometer's rotation, height and tilt can be changed to properly position it for the testing or rehab pattern being used. For all standard patterns, the Patient Setup Window displays prompts to help the clinician position the dynamometer.

Do not apply any lubricant or cleaning solution other than alcohol to the dynamometer pedestal. It is important however, to keep the pedestal clean to ensure proper clamping.

Adjusting the Dynamometer's Rotation and Height

- Release the *Dyna Pedestal Clamp* by using either your foot or hand to lift up on either clamp handle.
- Grasp the dynamometer and turn it to the desired position.
- Adjust the height by pulling up on the dynamometer to raise it or pushing down to lower it.
- Tighten the clamp by either stepping or pushing down on the clamp handle.
- The positions shown on the *Dyna Rotation Scale* and the *Dyna Height Scale* can be entered into the patient's record at the software application's Patient Setup Window.

Adjusting the Dynamometer Tilt

- Although the dynamometer tilt is counterbalanced, the various size and weight adapters may require the user to steady the unit with one hand so that it will not tilt forward or backward when the tilt mechanism is loosened.
- Loosen the *Tilt Handle*, located on the side of the dynamometer, by turning it counterclockwise (CCW).

- Tilt the dynamometer head until the pointer lines up with the desired setting on the *Dyna Tilt Scale*.
- Ensure that the teeth on the dynamometer locking mechanism are properly aligned, then lock the dynamometer in position by turning the tilt handle clockwise (CW).

The positions shown on the *Dyna Tilt Scale* can be entered into the patient's record at the software application's Patient Setup Window.

USING INPUT ADAPTERS

Each testing and rehab pattern on the CSMI NORM System requires specific input and stabilization accessories. To ensure patient safety and the accuracy of test results, it is important to take some time to learn the correct way to install each device. For quick and accurate identification, each adapter is engraved with its name.

Input Adapters and Accessories

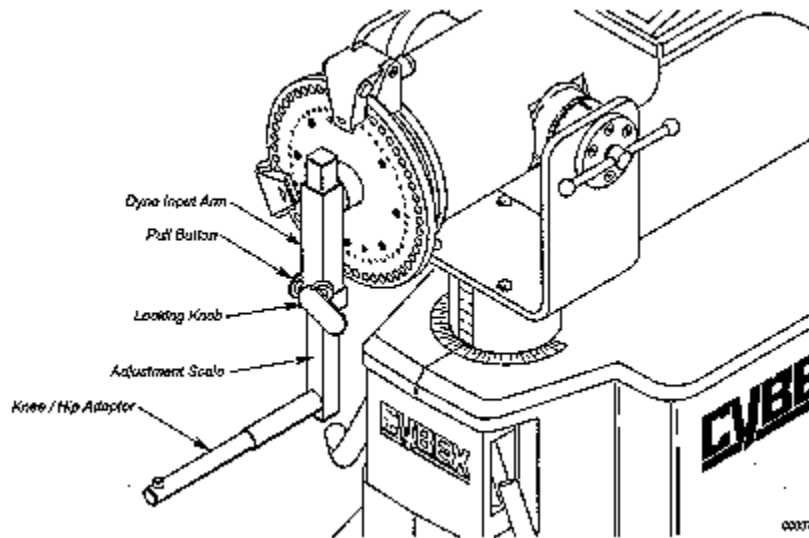

Figure 2-5 Dynamometer Input Arm

Dynamometer Input Tube and Locking Knob: The *Dynamometer Input Tube* is permanently attached to the dynamometer. Notice that one end of it is equipped with a *Locking Knob*. Accessories are attached to the dynamometer by inserting them through an end of the input tube and tightening the knob.

Push Button: The Knee/Hip Adapter has a Push Button. Pressing this button allows accessories such as the Knee/Hip Pad to be positioned on the accessory.

Scales: For set-up consistency, many of the accessories contain a scale to permit the clinician to record insertion length. The scale is read from the color code.

Attaching an Adapter to the Dynamometer

- Loosen the Locking Knob by turning it counterclockwise (CCW).
- Insert the adapter into the input tube to the desired length then tighten the locking knob.

THE RECLINING CHAIR

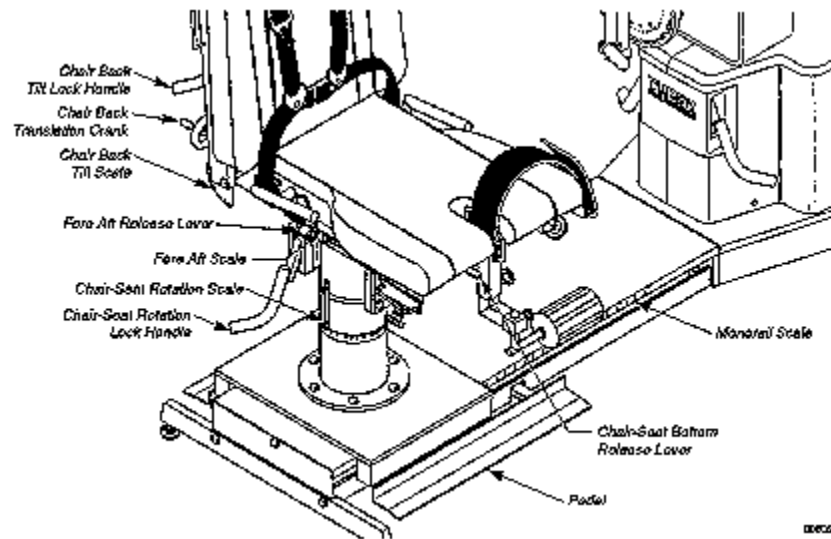

Figure 2-6 Reclining Chair Adjustment Scales

Ergonomically designed to ensure proper anatomical positioning, stabilization and patient comfort for both lower limb patterns and upper body testing and rehabilitation, the *Reclining Chair* is adjustable and scaled for ease in reproducing settings.

The placement of the chair relative to the dynamometer establishes a standardized body position for test reproducibility. The patient can then be properly aligned so that the axis of the joint being tested is in line with the input shaft of the dynamometer.

The exact placement for proper alignment needs to be individually determined by aligning the rotational axis of the joint (in the neutral position) to be tested with the input shaft of the dynamometer. Minor adjustments may be made for patient comfort and smoothness of motion. Scales are provided on the chair so that their values can be recorded into the patient's software set-up record for reliable repeat positioning during subsequent sessions.

Note that small errors in aligning a joint's axis of rotation with the input shaft of the dynamometer have no significant effect on the accuracy of torque measurement. In fact, some movements do not have a true central axis of rotation (e.g., ankle inversion /eversion) or have an axis that changes throughout the movement (e.g., shoulder abduction/adduction). In such cases, it is necessary to select a "compromise" axis. This will not appreciably affect the data gathered through testing. (Extensive testing has shown that most errors not large enough to affect smoothness of movement or restrict active range of motion will not affect torque production by more than 1%).

Using the Reclining Chair During a Session

The Reclining Chair assures stability during testing or rehab sessions. It provides the appropriate stabilization for the torso, hips, waist, thighs and the contralateral limb.

Multiple adjustment angles allow patients to be set-up in sitting, prone or supine positions for extremity testing or rehab. For each adjustment on the reclining chair there is a corresponding scale to enable the clinician to record the patient's exact set-up position into the patient's software set-up record.

The chair can be moved forward or back along the monorail to adjust its distance from the dynamometer. It can also be moved fore and aft on its pedestal and rotated through 360° to obtain the best possible patient position angle.

The chair-back can be reclined from vertical for seated patterns to horizontal for prone or supine patterns. For seated patterns, the chair-back can be cranked forward to meet the patient's back and the chair-seat can be raised or left flat.

ADJUSTING THE RECLINING CHAIR

The Reclining Chair is moved along the Monorail by stepping on either *Foot Pedal*. The chair assembly itself can be moved forward or backward on its pedestal by unlocking the Fore/Aft Lever. The chair seat bottom can be angled up by lifting the seat. It can be lowered by pushing down on the Seat Release Lever. The seat back can be positioned from fully upright to fully reclined by releasing the Recline Lever. Additionally, the chair back can be translated to accommodate different femur lengths by rotating the Translation Crank. For each adjustment on the reclining chair there is a corresponding scale to enable the clinician to record the patient's exact set-up position into the patient's software set-up record. Refer to Figure 2-6 for adjustment lever and scale locations.

Moving the Reclining Chair along the Monorail

The reclining chair is moved along the monorail to the appropriate distance from the dynamometer in order to attain the alignment of the patient's axis of rotation with that of the dynamometer. A scale, located on both sides of the monorail, provides reproducible placement of the chair pedestal.

To move the chair along the monorail

- Release the reclining chair by stepping on either Foot Pedal. While holding the pedal down, grasp the chair and slide it along the monorail.
- Lock the chair in place by taking your foot off the Foot Pedal.

✓ *Always ensure that the chair is secure.*

The chair's position, shown on the *Monorail Scale*, can be recorded into the patient's record at the software application's *Patient Setup Window*.

Rotating the Reclining Chair

To rotate the Reclining Chair

- Release the Chair Pedestal Clamp by using either your foot or hand to lift up on either clamp handle.
- Grasp the chair and turn it to the desired position.
- Tighten the clamp by either stepping on or pushing down on the clamp handle.

Enter the position shown on the *Chair Rotation Scale* into the patient's record at the software application's *Patient Setup Window*.

Adjusting the Reclining Chair's Fore/Aft Position

For fine tune adjusting of individual patient's anatomical axis with the dynamometer's axis, move the chair forward or backward on the pedestal.

To adjust the fore/aft position

- Unlock the seat by pulling up on the *Fore/Aft Lever*.
- Move the seat backward or forward to the desired position.
- Push down on the *Fore/Aft Lever* to lock the chair in position.

The axis position, shown on the *Fore /Aft Scale*, can be recorded into the patient's record at the software application's *Patient Setup Window*.

✓ *Always ensure that the chair is secure.*

Adjusting the Chair's Seat

The chair's seat has settings for Up (angled) or Flat (horizontal). Some seated patterns such as knee extension flexion, are performed with the chair seat in its angled position.

To raise or lower the chair-seat

- To raise the seat to its angled position, lift it up.
- To lower the seat hold it, and while pushing down on the Seat Release Lever, lower the seat.

✓ *A patient should not be on the chair when the seat is being raised or lowered. When adjusting the seat, keep your hands and fingers away from areas where they might be pinched (i.e., between underside of seat and chair frame).*

Adjusting the Chair's Back

The chair-back can be positioned from vertical to horizontal. For most upright test and exercise patterns (e.g., knee extension/flexion) the seat back should be set to 85° or 90° as indicated on

the *Chair-Back Rotation Scale*. For patterns using prone or supine positioning, place the seat back in its most reclined position.

To adjust the chair-back recline Angle

- Unlock the seat back by pulling out on the *Recline Lever*.
- Adjust the chair-back's support angle by using the grab bar to move the back to the desired position.
- Push down on the *Recline Lever* to lock the seat back in place.

The chair-back's position, shown on the *Chair-Back Rotation Scale*, can be recorded into the patient's record at the software application's *Patient Set-Up Window*.

- ✓ **Caution:** Do not adjust the chair-back recline angle while the patient is on the chair. The chair-back angle should be adjusted before the patient is positioned on the chair or bed. Appropriate chair-back angles are indicated in the set-up instructions for each pattern.

To adjust the Chair's Back for Lumbar Support

- Rotate the *Crank* counter clockwise (CCW) to move the chair-back forward to meet the patient's back.
- Rotate the *Crank* clockwise (CW) to move the chair-back aft.

The position shown on the *Position Scale* can be recorded into the patient's record at the software application's *Patient Set-Up Window*.

Adjusting the Lumbar Cushion

The reclining chair has a removable lumbar cushion which can be placed by the clinician for proper positioning and individualized patient comfort.

Attaching Accessories to the Chair

The chair is fitted with three Receiving Tubes which are used to support patient stabilization accessories. For each joint test pattern, when applicable, the Patient Setup Window notes the proper receiving tube immediately following the respective part name. Insert the accessory into the receiving tube and secure the locking knob. In Figure 2-7 the contralateral limb stabilizer is secured in receiving tube #2.

STABILIZATION ACCESSORIES

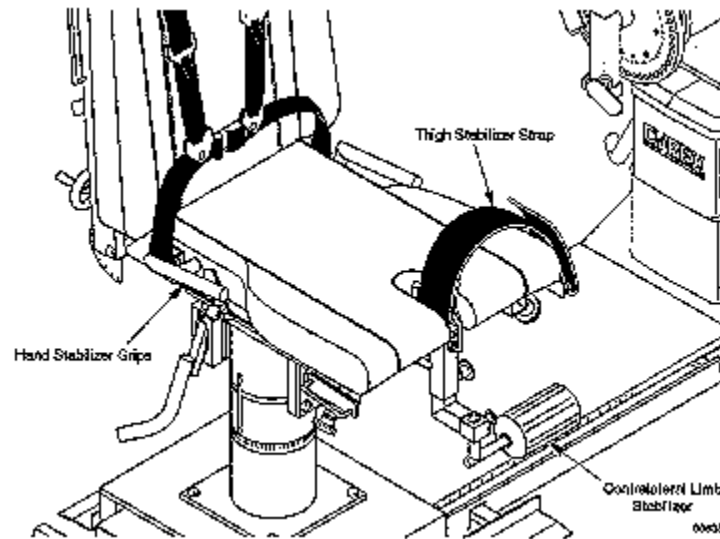

Figure 2-7 Contralateral Limb Stabilizer & Handle Bars

Contralateral Limb Stabilizer: The *Contralateral Limb Stabilizer* is used primarily during testing or exercise of the knee to prevent unwanted movement of the contralateral limb. The patient tucks the contralateral limb behind this stabilizer and to keep it there throughout the duration of the test or exercise session.

Handle Bars: *Handle Bars* are located on either side of the reclining chair. They provide the patient with a firm grip and reproducible hand positioning during a rehab session on the NORM System. Use of the handle bars is not recommended during testing.

Velcro Belts: *Velcro belts* are used to help stabilize the patient or to attach the input mechanism to the limb being tested. To ensure patient safety as well as proper stabilization and positioning, it is vital that these belts be adjusted so that they have sufficient gripping power and that they are as tight as tolerable for each patient.

- ✓ *The belts used on many components, particularly the shin pad and thigh stabilization belt used for knee patterns, absorb large and repetitive loads. To ensure patient safety, it is important to check regularly for signs of wear. Any belt with significant wear should be immediately replaced. Keeping extra shin pads and stabilization belts on hand ensures timely replacement and avoids possible injury or down-time.*

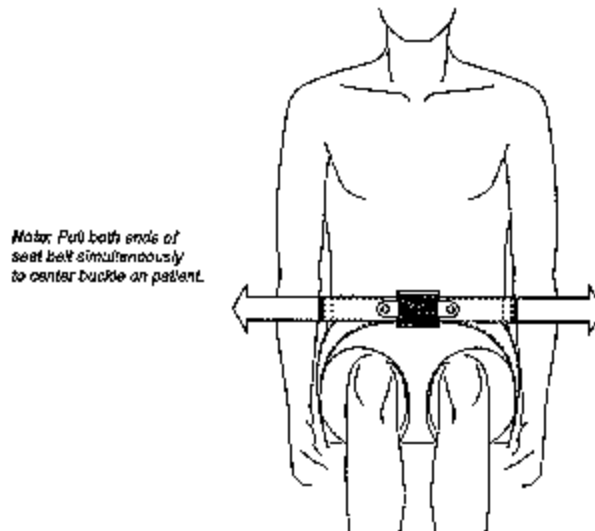

Figure 2-8 Seat Belt Adjustment

Seat Belt: The *Seat Belt* provides safe comfortable stabilization across the patient's pelvic area. Secure the seat belt before fastening the shoulder belts.

- ❖ If the patient is wearing a dress belt on his/her pants, have him/her remove it before fastening the seat belt.
- Pull the seat belt from both ends so that the belt buckle is in the center of the patient's waist and fairly snug.

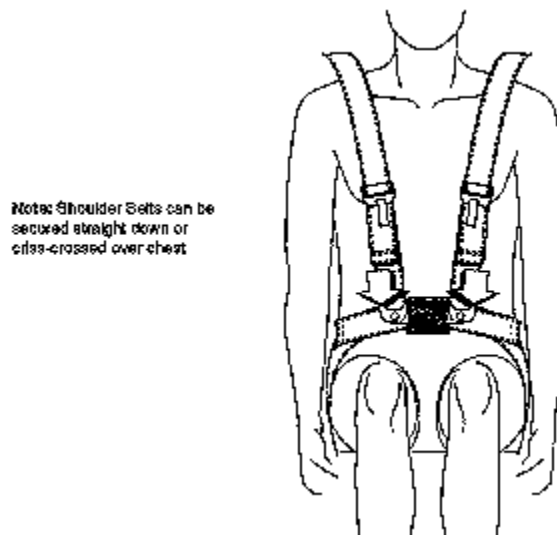

Figure 2-9 Shoulder Stabilization Belts

Shoulder Stabilization Belts: To provide safe, comfortable stabilization of the shoulders and chest, two *Shoulder Stabilization Belts* are secured either straight down or across the patient's

chest. Each belt is snapped onto the seat belt buckle and tightened as snugly as tolerable by the patient to discourage substitution during testing or exercise.

- To tighten a shoulder belt, grasp the seat belt buckle with one hand and pull up on the free end of the shoulder belt with the other until the slack is taken up.
- To loosen the shoulder belt, lift up on the belt adjustment clip and pull on the belt until it is loosened appropriately.

Note: *Shoulder Belts* can be secured straight down or criss-crossed over chest.

Torso Stabilization Belt: The *Torso Stabilization Belt* is used during shoulder and hip testing for upper torso stabilization.

- The ends of the torso stabilization belt are looped through the grab bars located on either side of the chair—back and snugly fasted around the patient’s torso.

Forearm Stabilization V-Pad: The *Forearm Stabilization V-Pad* is used to provide stabilization to the forearm during wrist pattern testing.

- The Forearm Stabilization V-Pad fits onto the Thigh/Forearm Stabilizer Arm which in turn is inserted into chair receiving tube #2.

Thigh Stabilization Pad: The *Thigh Stabilization Pad* provides stabilization and support to the thigh during ankle pattern testing. For patient comfort, the pad position can be translated on the Thigh/Forearm Stabilizer Arm.

- The *Thigh Stabilization Pad* fits onto the Thigh/Forearm Stabilizer Arm which in turn is inserted into chair Receiving Tubes #2.
- The position of the *Thigh Stabilization Pad* and *Stabilizer Arm* can be recorded in the patient’s record at the software application’s Patient Set-Up Screen.

Elbow Stabilization Pad: The *Elbow Stabilization Pad* supports the elbow joint during shoulder testing.

- To attach the *Elbow Stabilization Pad* to the *Dynamometer Input Arm*, angle it slightly and insert it onto the short end of the input tube. Tighten the *Locking Knob*.

SECTION 3. PATTERN SELECTION AND SETUP

This chapter of the User's Guide describes the Pattern Selection Window and provides a guide for extremity and trunk testing set-ups on the CSMI NORM Testing and Rehabilitation System.

In addition to testing, the NORM System also serves as a uniquely versatile and effective rehabilitation unit. The NORM System and its accessories are designed to be adaptable to the needs of patients, treatment methods and ideas. With a little imagination, this system may be applied to many types of treatment programs and to the specific needs of a wide variety of orthopedic and neurologic patients. Patients may be exercised in prone, supine, sitting or standing positions. Patient axis of rotation may be oblique or offset to include motions of the trunk.

The scale and positioning values listed in the standard pattern set-up instruction charts included in this chapter are intended to guide the clinician in the proper anatomical set-up for a wide patient population. Specific, individual positioning however, is left to the discretion of the clinician.

Each joint, and the trunk, requires specific considerations that can effect the testing or rehabilitation process. Most frequently these concern:

- Optimal positioning and stabilization of the limb (or trunk) being tested.
- Locating the true or best possible axis of rotation to allow maximum functional range of motion and a smooth comfortable movement for the patient.
- Selection of appropriate test and exercise speeds.
- Determination of the joint's zero degree or neutral position.

The **Biomechanical Considerations** section preceding each series of patterns covers this and other information pertinent to the anatomy of the particular joint or trunk and should be kept in mind when testing or exercising.

TESTING AND EXERCISE OF THE KNEE

Biomechanical Considerations

Possibly the most frequently injured extremity joint, the knee, is the easiest to test and exercise on the CSMI NORM System. As a result, considerable data has been generated regarding testing protocols and norms for this joint. As with other joints, correct axis alignment is essential to insure patient safety and valid test results.

All of the major knee flexors, as compared to only one of the major knee extensors, are two-joint muscles with origins above the hip joint. This fact dictates the optimal testing and exercise position for knee extension/flexion as established by the reclining chair. Proper positioning allows the flexors to be worked at an advantageous and reproducible length/tension relationship without restricting extensor range of motion. A number of studies have verified that this positioning produces maximum flexor and extensor forces with excellent reproducibility. It is also convenient and comfortable for most patients. If this positioning is not practical or appropriate for certain patients (e.g., extensors require gravity assist, hip flexion limited to less than 90°), positioning the patient prone on the reclining chair is a recommended alternative.

Extension/Flexion Considerations

Anatomical landmarks of the knee are palpated so that the axis of rotation for testing is readily located. The mixed gliding and rocking motion of the knee joint in extension/flexion does cause this axis to shift slightly as the tibial plateau slides anteriorly during extension and posteriorly during flexion. However, this small shift has no significant effect on the patient's torque production.

Most frequently, anatomical problems presented in knee testing deal with patient comfort and/or normal hyperextension of the joint. While it is desirable to maximally stabilize the thigh in extension/flexion, insufficient padding underneath the thigh or securing the thigh belt too tightly can cause enough discomfort to inhibit force output.

The degree of hyperextension in a knee test is affected by the test speed. At slow test speeds, no hyperextension may be noticeable. At higher test speeds, the inertia of the limb tends to help the contracting muscles overcome the passive resistance of skin, fascia and articular structures so that significant hyperextension may occur. It is also possible for the thigh to slightly lift off the chair during high speed testing.

These factors have no significant effect on torque measurement except during the first one-eighth second of a high-torque contraction, during which the limb compresses the foam padding of the reclining chair and shin pad and "takes up slack" in the thigh belt. They can, however, combine to produce errors of $\pm 5^\circ$ relative to the position angle, depending on force and direction of movement. This degree of error occurs only in the knee extension/flexion test. It is considered acceptable in clinical applications because the overall range of motion measurement is quite accurate and the position of any specific torque measurement can be closely identified.

Speed selection for the extension/flexion pattern must be made after consideration of possible patellofemoral injury. At lower speeds, there are greater compressive forces on the joint. In cases where patellofemoral disorders are a factor, movement at 60 deg/sec. through full range of motion may be too slow. Choosing higher velocities will reduce patellofemoral compressive forces. Starting speeds of 90 to 120 deg/sec. may be more appropriate. Short arc exercises may also be prescribed for slow speeds (i.e., 60 deg/sec.) and ramping may be used to allow the patient enough time to generate torque.

Limiting range of motion is extremely important with some patients. Certain pathologies (i.e., ligamentous injuries or joint reconstruction) may require limited terminal extension or full flexion movements during the initial stages of rehabilitation. Limiting range of motion in the knee extension/flexion pattern is accomplished, when indicated, through the application's range limiting capabilities.

Testing and exercising the tibial internal/external rotation pattern is also quite important. The popliteus and medial hamstrings (as internal rotators) can play a significant role in supporting the knee with rotatory and/or anterior or posterior instability. Pesanserinus transfer may further enhance this action. Clinical study has demonstrated that specific rehabilitation in this pattern is essential for maximum functional return in many cases. Furthermore, testing this movement pattern provides data on the specific functional capability of these muscles. Also to be considered in anterior instabilities is the importance of the gastrocnemius, which helps counteract anterior sliding. It should be noted that stretching unstable ligaments in the tibial internal/external rotation position may, depending on the patient's condition, be desired or contraindicated.

For further research, refer to the *CSMI Bibliography of Isokinetic Research, Clinical Study and Observation*.

KNEE: EXTENSION/FLEXION (SEATED)

Parts Needed

- Knee/Hip Adapter
- Knee/Hip Pad
- Contralateral Limb Stabilizer
- Lumbar Cushion

Scale or Position	Scale or Position Setting	Right Limb Scale	Left Limb Scale
Chair Rotation Scale	40°	Teal	Black
Chair-Back Angle	85°		
Chair-Seat position	Up		
Dyna Tilt Scale	0°		
Dyna Height Scale	8		
Dyna Rotation Scale	40°	Teal	Black
Monorail Scale	38		

Reclining Chair Preparation

- Install Contralateral Limb Stabilizer in chair receiving tube #2 (if indicated.)

Dynamometer Preparation

- To install adapter on dyna input arm:
 1. Secure Knee/Hip Pad on Knee/Hip Adapter with the pad offset toward the dynamometer.
 2. Insert adapter into long end of input arm and secure.

Position Patient

- Position patient appropriately on chair; provide Lumbar Cushion (if indicated.)
 1. Have patient move forward or back on seat until the knee is just lightly touching the chair-seat cushion.
 2. Rotate Crank to adjust chair-back to meet patient's back.
 3. Secure Seat Belt and Shoulder Belts.
- Chair-Seat Fore/Aft: Move and secure chair at an appropriate distance from dyna to properly align knee axis of rotation with dyna axis.
- Position Knee/Hip Pad on patient's leg and secure.
- Secure Thigh Stabilizer Strap.
- Test patient's ROM. Adjust set-up if required.
- Record all scale values and click OK.

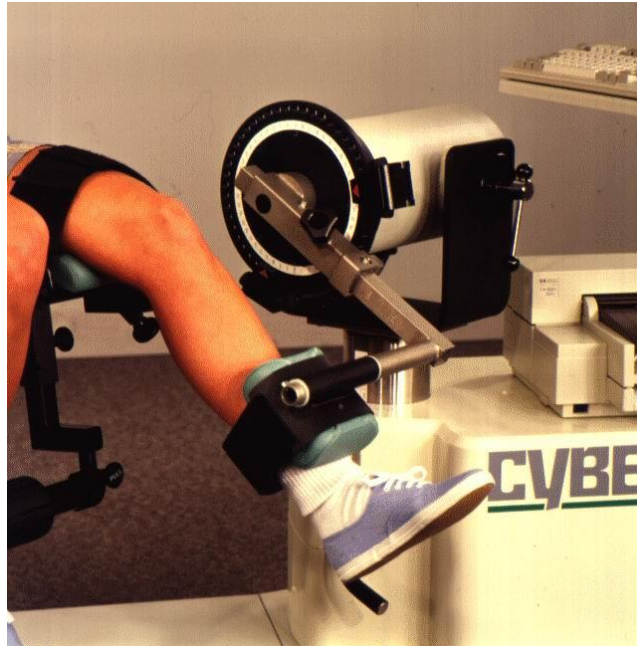
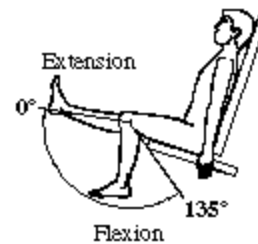

Figure 3-1 Knee: Extension/Flexion - Seated.

The most accurate fixed axis for rehab or testing of the knee is a line passing transversely through the femoral condyles.



Pattern Begins in Full Flexion

Before Conducting the Session

- Check that all clamps and knobs are secure.
- Check that the mechanical ROM stops are properly positioned according to the patient's range of motion, and that they are secure, before conducting the session.

KNEE: EXTENSION/FLEXION (PRONE)

Parts Needed

- Knee/Hip Adapter
- Knee/Hip Pad
- Torso Belt
-

Scale or Position	Scale or Position Setting	Right Limb Scale	Left Limb Scale
Chair Rotation Scale	40°	Black	Teal
Chair-Back Angle	0°		
Chair-Seat position	Flat		
Dyna Tilt Scale	0°		
Dyna Height Scale	5		
Dyna Rotation Scale	40°	Black	Teal
Monorail Scale	End		

Reclining Chair Preparation

- Chair-Seat Fore/Aft Scale: Move and secure at position **15**.

Dynamometer Preparation

- To install adapter on dyna input arm:
 1. Secure *Knee/Hip Pad* on *Knee/Hip Adapter* with the pad offset toward the dynamometer.
 2. Insert adapter into long end of input arm and secure.

Position Patient

- Position patient appropriately on chair.
- Position Knee/Hip Pad on patient's leg and secure.
- Secure Thigh Stabilizer Strap on involved calf.
- Secure *Torso Belt* around pelvis.
- Test patient's ROM. Adjust set-up if required.
- Record all scale values and click OK.

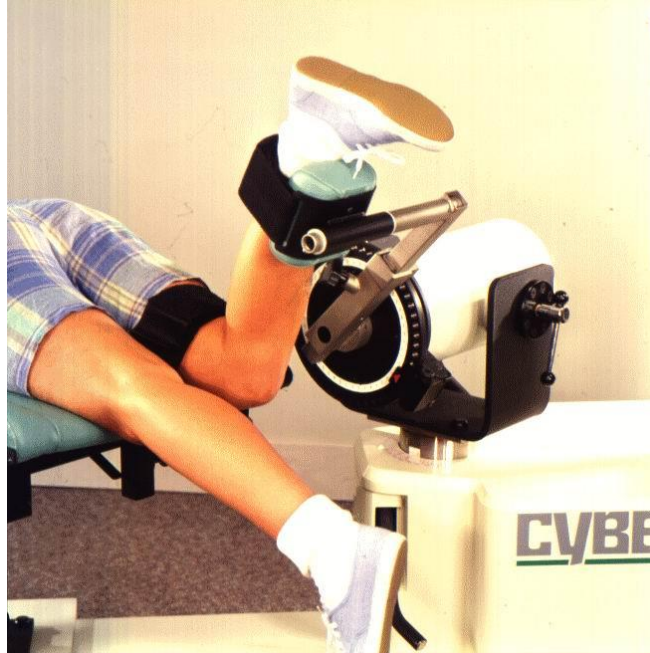
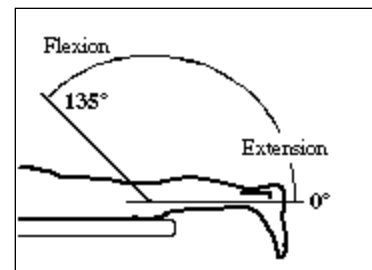

Figure 3-2 Knee: Extension/Flexion - Prone.

The most accurate fixed axis for rehab or testing of the knee is a line passing transversely through the femoral condyles.

Pattern Begins in Full Flexion



Before Conducting the Session

1. Check that all clamps and knobs are secure.
2. Check that the mechanical ROM stops are properly positioned according to the patient's range of motion, and that they are secure, before conducting the session.

KNEE: TIBIAL INTERNAL/EXTERNAL ROTATION

Parts Needed

- Ankle Adapter
- Footplate
- Footrest
- Thigh Stabilizer Pad
- Thigh/Forearm Stabilizer Tube
-

Scale or Position	Scale or Position Setting	Right Limb Scale	Left Limb Scale
Chair Rotation Scale	85°	Teal	Black
Chair-Back Angle	0°		
Chair-Seat position	Flat		
Dyna Tilt Scale	30°		
Dyna Height Scale	0		
Dyna Rotation Scale	10°	Black	Teal
Monorail Scale	72		

Reclining Chair Preparation

- Secure Thigh Stabilizer Pad on Thigh/Forearm Stabilizer Tube, then insert stabilizer tube into chair receiving tube #2.

Dynamometer Preparation

- To install adapter on dyna input arm:
 1. If Counterbalance weight is on Footplate, remove it.
 2. Insert Footplate all the way into Ankle Adapter tube labeled INT/EXT rotation and secure.
 3. Rotate the long end of the dyna input arm to 6 o'clock position.
 4. Insert Ankle Adapter into the short end of input arm and secure.

Position Patient

The patient should be wearing appropriate footwear such as sneakers.

- Position patient appropriately on chair.
- Install footrest (angled down) into chair receiving tube #3 for Right knee or #1 for Left knee.
- Chair-Seat Fore/Aft: Move and secure chair at an appropriate distance from dyna to properly position patient's foot on Footplate.

- With foot on Footplate, adjust dyna height and Thigh Stabilizer Tube height so patient's knee is at 90° flexion and hip at 60° flexion. Strap foot on Footplate. (Patient may need to slide up or down on bed.)
- Secure the Thigh Stabilizer Pad proximal to the knee joint line.
- Fasten Seat Belt around pelvis.
- Test patient's ROM. Adjust set-up if required. Record all scale values and click OK.

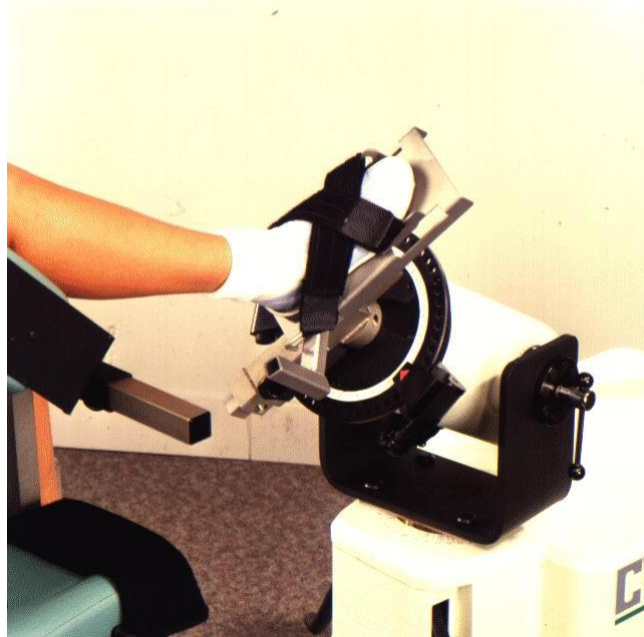
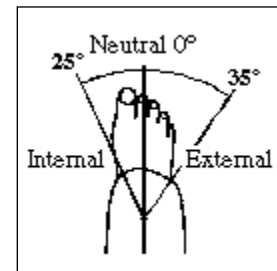

Figure 3-3 Knee: Tibial Internal/External Rotation.

The axis of rotation is slightly medial to the longitudinal axis of the tibia. This can be visualized, approximated and then fine adjusted during warm up / familiarization repetitions.



Pattern begins in Full External Rotation

Before Conducting the Session

1. Check that all clamps and knobs are secure.
2. Check that the mechanical ROM stops are properly positioned according to the patient's range of motion, and that they are secure, before conducting the session.

TESTING AND EXERCISE OF THE ANKLE

Biomechanical Considerations

The ankles must support at least the full weight of the body. During heavy labor or sports activities, the musculature and structures of the ankle and foot must absorb and transmit the tremendous forces produced by the body's most powerful muscles. The ankle is a multi-joint system, but two primary joints dominate ankle testing. For the extension/flexion pattern, the talocrural joint is most dominant while the subtalar joint predominates in the inversion/eversion pattern.

Because of the more distal insertion of all the extrinsic muscles of the foot and ankle, a contraction of any of these muscles applies some degree of force through all the ankle joints. Whether the foot is on the ground or secured to a CSMI footplate, the intrinsic muscles of the foot must simultaneously contract to appropriately stabilize the metatarsophalangeal joints. These contractions are necessary to transmit forces to the footplate (and for normal movement) but do not add significantly to torque measurement because they are distal to the test axis. Furthermore, because of the way the foot is strapped onto the footplate, no measurable additional movement occurs.

Except for the bent knee patterns which emphasize the soleus muscle, hip and knee angles within the ranges illustrated and specified have no significant effect on ankle torque production or range of motion. In some body positions, however, it is easier for the patient to apply unwanted input forces from hip and knee musculature. Patients must be observed, properly instructed and stabilized to ensure this does not occur. The following rule of thumb applies to any dynamic isolated-joint test:

If there is no movement proximal to the joint being tested, there is no significant substitution or added force from other joint musculature. Conversely, significant proximal movement indicates some degree of substitution.

When testing the ankle, more than ½" up-down movement of the knee indicates improper alignment. Adjusting the footplate tube length should reduce or eliminate the up-down movement. More than ½" side-to-side movement indicates insufficient stabilization or active substitution by a patient who does not understand the movement pattern required. Give further instructions to the patient, check the security of thigh and footplate belts and provide manual stabilization if necessary. Use of the stabilization belts are recommended more for patient safety than for needed stabilization. If the patient's body is moving around on the reclining chair during ankle testing, it is likely that considerable extraneous forces are being produced.

It should be noted that most of the muscles that move the ankle (dorsiflexors, primary inverters and everters) are small and do not have a large blood supply. This may become apparent during endurance testing, as some patients will complain of fairly intense discomfort ("muscle burning") during and briefly following high-speed testing or rehab exercise. These patients may also find it uncomfortable to be left strapped into the footplate after completion of the bout.

Plantar/Dorsiflexion Considerations

To be properly stabilized in the footplate, patients must wear a cross trainer, mid-high or high-top type shoe with a flat heel. Angled heels (common on running shoes) will not allow proper stabilization. Footplate belts should be tightly secured. Untie shoelace knot if it causes discomfort and/or reposition belts slightly if necessary for patient comfort.

Only one muscle that significantly affects ankle movement originates above the knee. This is the gastrocnemius, a primary plantar flexor that also participates to a degree in the inversion/eversion movement as performed on the CSMI NORM System. Because of its origin, the length/tension relationship of this muscle is changed by the angle of the knee particularly affecting its plantarflexion torque capability, which is greatest in full extension. It is therefore recommended that plantar/dorsiflexion testing be done in full knee extension to emphasize the gastrocnemius and, in 90° of flexion, to emphasize the soleus. If testing is performed in other positions, knee angles should always be noted for subsequent reproducibility.

The major axes of rotation for ankle movement are difficult to visualize and establish. Fortunately, there is enough mechanical play in the joints to compensate for small positioning errors without significantly affecting torque measurement or range of motion. The axis for plantar/dorsiflexion is at an oblique angle to the leg.

Inversion/Eversion Considerations

The axis of rotation used for the inversion/eversion movement as performed on the CSMI NORM System produces a compound motion of the upper, lower and transverse tarsal joints. Some authorities have described this compound motion as supination (a combination of plantarflexion, adduction and inversion) and pronation (a combination of dorsiflexion, abduction and eversion). This motion provides the greatest possible work potential and ROM for all the muscles responsible for medial and lateral ankle stabilization and movement. Weakness and/or imbalance in this musculature are critical indicators or predictors of injury.

For inversion/eversion testing, the gastrocnemius is at a significant biomechanical disadvantage and produces only small forces. However, patients should be positioned with no less than 30° and no more than 75° of knee flexion to insure maximum test reproducibility. This knee angle range is more than sufficient to establish the neutral ankle position required for testing.

Undesirable movement in this pattern can be blocked manually. At slow test speeds, some patients can self-limit range of motion. Similar to post-op knees, some clinicians have explained that the "safe" range of motion for early post-op movement should be identified during surgery so that rehabilitation can be started earlier. This applies to other body joints as well. Since weight bearing is often contraindicated for long periods following surgery, these movement patterns may help prevent muscle atrophy and can be done without weight bearing.

ANKLE: PLANTAR/DORSIFLEXION (PRONE)

Parts Needed

- Ankle Adapter
- Footplate

Scale or Position	Scale or Position Setting	Right Limb Scale	Left Limb Scale
Chair-Back Translation	0		
Chair Rotation Scale	50°	Black	Teal
Chair-Back Angle	0°		
Chair-Seat position	Flat		
Dyna Tilt Scale	0°		
Dyna Height Scale	3		
Dyna Rotation Scale	55°	Black	Teal
Monorail Scale	38		

Reclining Chair Preparation

- Refer to above chart.

Dynamometer Preparation

- To install Ankle Adapter on dyna input arm:
 1. If the Counterbalance weight is on the Footplate, remove it.
 2. Insert Footplate into Ankle Adapter tube labeled PF/DF and secure at a proper position for the height of the patient's ankle.
 3. Rotate short end of the dyna input arm to 12 o'clock.
 4. Insert Ankle Adapter into short end of input arm and secure.

Position Patient

The patient should be wearing appropriate footwear such as sneakers.

- Position patient appropriately on chair and fasten Seat Belt around pelvis.
- Chair-Seat Fore/Aft position: Move & secure at an appropriate distance from dyna to properly position patient's foot on footplate.
- Strap patient's foot on Footplate.
- Secure Thigh Stabilizer Belt on the involved leg.
- Test patient's ROM. Adjust set-up if required.
- Record all scale values and click OK.

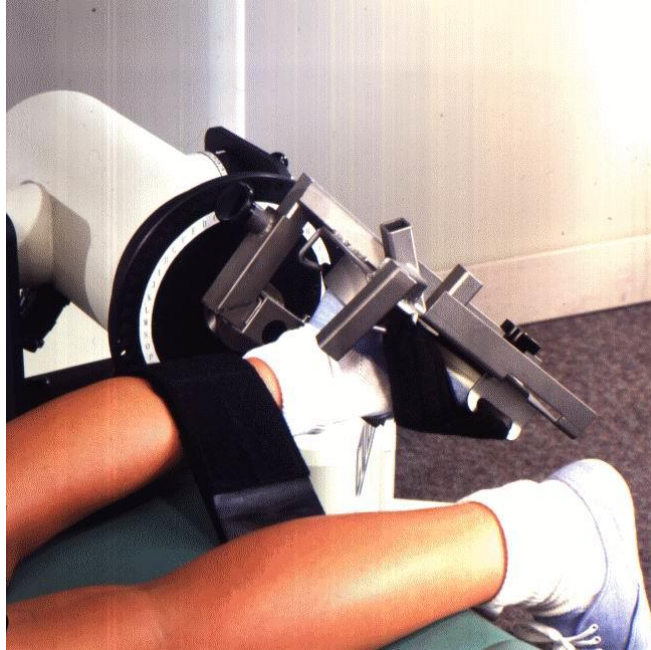
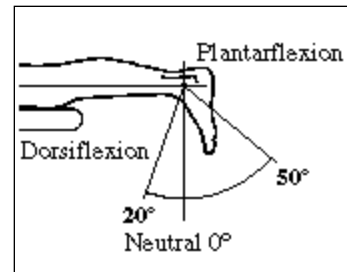

Figure 3-4 Ankle: Planter/Dorsiflexion Prone

The Ankle Plantar / Dorsiflexion axis of rotation passes obliquely (approximately 16° anteromedially) through the tip of the fibula (lateral malleolus) and the trochlea of the talus exiting just distal to the tip of the tibia (medial maleolus). This is accomplished by appropriately positioning the foot on the footplate.



Pattern Begins in Full Dorsiflexion.

Before Conducting the Session

- Check that all clamps and knobs are secure.
- Check that the mechanical ROM stops are properly positioned according to the patient's range of motion, and that they are secure, before conducting the session.

ANKLE: PLANTAR/DORSIFLEXION (SUPINE)

Parts Needed

- Footplate
- Counterbalance Weight (.8kg)
- Ankle Adapter
- Thigh Stabilizer Pad
- Thigh/Forearm Stabilizer Tube
- Footrest

Scale or Position	Scale or Position Setting	Right Limb Scale	Left Limb Scale
Chair-Back Translation	0		
Chair Rotation Scale	50°	Teal	Black
Chair-Back Angle	0°		
Chair-Seat position	Flat		
Dyna Tilt Scale	10°		
Dyna Height Scale	10		
Dyna Rotation Scale	55°	Teal	Black
Monorail Scale	39		

Reclining Chair Preparation

- Insert Thigh Stabilizer Pad on Thigh/Forearm Stabilizer Tube, then insert stabilizer tube into chair receiving tube #2.

Dynamometer Preparation

- To install adapter on dyna input arm:
 1. Screw Counterbalance weight into Footplate heelcup.
 2. Insert Footplate into Ankle Adapter tube labeled PF/DF and secure at a proper position for the height of the patient's ankle.
 3. Rotate long end of dyna input arm to 12 o'clock.
 4. Insert Ankle Adapter into short end of input arm and secure.

Position Patient

The patient should be wearing appropriate footwear such as sneakers.

- Position patient appropriately on chair DO NOT fasten Seat Belt yet.
- Install Footrest into chair receiving tube #3 for Right ankle and #1 for Left.
- With foot on footplate, adjust Thigh Stabilizer Tube height so patient's knee is at 90° flexion. Patient may need to slide up or down on bed.
- Stabilize patient's foot on Footplate. Adjust Input Arm penetration and Footplate penetration to align ankle axis of rotation with dyna axis.

- Chair-Seat Fore/Aft position: Move and secure chair at an appropriate distance from dyna to comfortably stabilize thigh with knee 90° flexed. Adjust Thigh Stabilizer if necessary.
- Test patient's ROM. Adjust set-up if required. (*A slight chair rotation may be all that is required.*)
- Fasten Seat Belt around pelvis. Record all scale values then click OK.

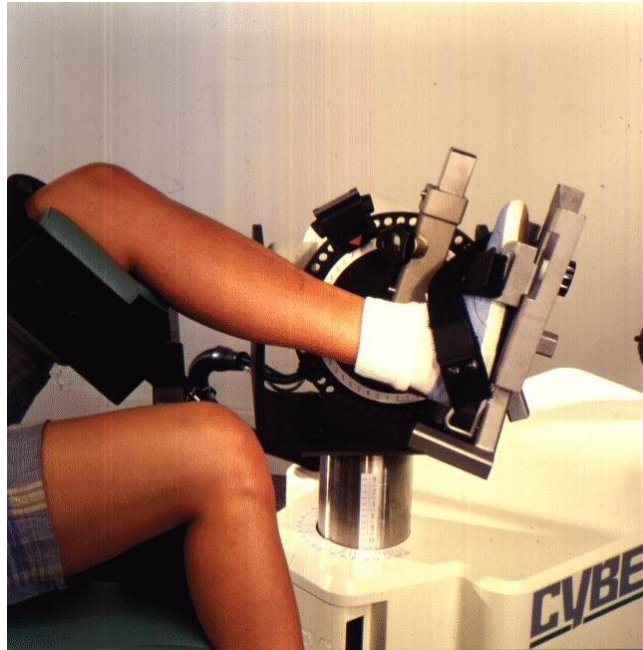
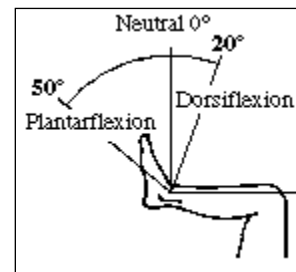

Figure 3-5 Ankle: Planter/Dorsiflexion Supine.

The Ankle Plantar / Dorsiflexion axis of rotation passes obliquely (approximately 16° anteromedially) through the tip of the fibula (lateral malleolus) and the trochlea of the talus exiting just distal to the tip of the tibia (medial maleolus). This is accomplished by appropriately positioning the foot on the footplate.



Pattern Begins in Full Dorsiflexion.

Before Conducting the Session

1. Check that all clamps and knobs are secure.
2. Check that the mechanical ROM stops are properly positioned according to the patient's range of motion, and that they are secure, before conducting the session.

ANKLE: INVERSION/EVERSION

Parts Needed

- Thigh Stabilizer Pad
- Thigh/Forearm Stabilizer Tube
- Ankle Adapter
- Footplate
- Footrest

Scale or Position	Scale or Position Setting	Right Limb Scale	Left Limb Scale
Chair Rotation Scale	85°	Teal	Black
Chair-Back Angle	0°		
Chair-Seat position	Flat		
Dyna Tilt Scale	55°		
Dyna Height Scale	0		
Dyna Rotation Scale	5°	Black	Teal
Monorail Scale	-		

Reclining Chair Preparation

- Install *Thigh Stabilizer Pad* on *Thigh/Forearm Stabilizer Tube*, then insert stabilizer tube into chair receiving tube #2.

Dynamometer Preparation

- Install Ankle Adapter on dyna input arm:
 1. If the Counterbalance weight is on the Footplate, remove it.
 2. Secure Footplate on Ankle Adapter; position for INV/EV.
 3. Position short end of dyna input arm at 12 o'clock.
 4. Insert Ankle Adapter into short end of input arm and secure.

Position Patient

The patient should be wearing appropriate footwear such as sneakers.

- Position patient appropriately on chair and fasten Seat Belt around pelvis.
- Install Footrest into chair receiving tube #3 for Right ankle and #1 for Left.
- Monorail Scale: Move and secure chair at an appropriate distance from dyna to properly position foot on Footplate.
- With foot on Footplate, adjust Thigh/Forearm Stabilizer Tube to position knee between 80°-110° flexion.
- Strap patient's foot on Footplate.
- Secure Thigh Stabilizer Pad proximal to knee joint line.
- Test patient's ROM. Adjust set-up if required. Record all scale values, then press OK.

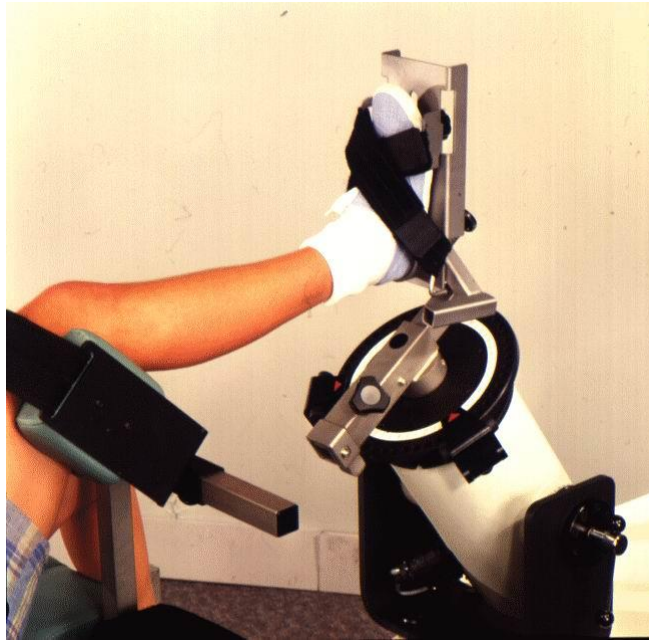
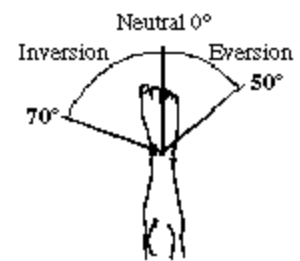

Figure 3-6 Ankle: Inversion/Eversion

The axis for Ankle Inversion / Eversion patterns is compound and changes throughout range of motion of the talocrural joint, talocalcaneal joint and talonavicular/calcaneocuboid or transverse tarsal joint.



Pattern begins in Full Eversion.

Before Conducting the Session

1. Check that all clamps and knobs are secure.
2. Check that the mechanical ROM stops are properly positioned according to the patient's range of motion, and that they are secure, before conducting the session.

TESTING AND EXERCISE OF THE SHOULDER

Biomechanical Considerations

Because it comprises several anatomical and physiologic joints, the shoulder has exceptional freedom of movement and should be thought of as a system rather than a series of individual joints. Four primary joints (sternoclavicular, acromioclavicular, glenohumeral and scapulothoracic) must move together to achieve global motion, each making a critical contribution to any specific movement. Because of this multi-joint configuration, functional shoulder movements rarely have a single or fixed axis of rotation. The axis of rotation for each joint when tested on the CSMI NORM System is, therefore, a compromised axis.

The sternoclavicular and acromio-clavicular joints allow the upward/downward movements and forward/backward rotation of the scapula relative to the chest wall (scapulothoracic motion) that are essential for all but a small range of shoulder movements. Because the humerus articulates with the scapula (glenohumeral joint), the effect of scapulothoracic motion is to continuously change the instantaneous axis of rotation of most shoulder movements throughout any given range of motion. This makes an individual's effective arm length longer at some points in the overall range of motion - particularly full abduction or forward flexion. These factors must be compensated for when determining input arm length setting and subject positioning. All shoulder patterns require that the shoulder testing accessory be set to a predetermined length for each patient.

Determining the most Effective Input Arm Length for Shoulder Abduction/Adduction, Extension/Flexion and Horizontal Abduction/Adduction Patterns.

- Measure in inches the distance from the lateral tip of the acromion process to the thumb webspace.
- To compensate for scapulothoracic motion, adjust the shoulder adaptor to a longer length than the patient's measured arm length.
- Instruct patient to keep wrist locked in neutral position during testing or exercise.
- Determining the most effective input arm length for Internal/External Rotation Patterns
- Measure from the elbow's lateral epicondyle to the thumb webspace.
- Adjust the length of the shoulder adapter closest to this measurement.
- During testing, patient's elbow should be flexed to 90° with forearm parallel to the dynamometer input arm.
- Instruct patient to keep wrist locked in neutral position throughout movement.

- With the patient in approximate testing position, adjust the shoulder rotation support so that the patient's arm is firmly wedged into the V-shaped pad and secure. This will lock the entire arm into position.

The critical rotatory movements of the scapula and clavicle cannot be accurately measured externally. However, these and other components of shoulder girdle movement, including glenohumeral motion, should be isolated and manually evaluated separately from CSMI tests. It is not possible to isolate these component motions in an active, dynamic test. All functional shoulder movements, particularly abduction, require coordinated, synchronous contractions of numerous muscles. Stabilization of the shoulder girdle is highly dependent on these same muscles because of inherent anatomical/mechanical laxity that gives the shoulder the greatest mobility of any body joint. Shoulder ligaments provide little articular stability. They are more specifically responsible for appropriately limiting range of motion.

The above factors make the shoulder vulnerable to a number of common injury mechanisms and also demand extra caution in exercise testing and rehabilitation programs. Care must be taken to prevent the joint from exceeding its safe range of motion capability in any movement pattern. The use of range of motion stops, in addition to the proper use of Chair accessories, will prevent movement into undesirable areas of the ROM. Frequently, external rotation and flexion must be guarded. Because the CSMI mechanism absorbs all of the patient's force capability and controls limb speed, blocking impact results only from the inertia of the limb and input arm even at high speed testing.

Manual stabilization may be required for patients who cannot use the involved limb to help stabilize the shoulder girdle when testing the uninvolved side.

During full active abduction, the humerus must be allowed to externally rotate so that the greater tuberosity does not impinge on the acromion and restrict range of motion. Conversely, to reach 0° abduction, the humerus must return to the neutral or 0° rotation position. The handgrip provided may be set to rotate freely during abduction/adduction testing or may have tension added for exercise. The selection of a measured input arm length simplifies the establishment of a workable axis of rotation for all shoulder movements.

Establishing the Axis of Rotation for Shoulder Movements

- Move the chair into position so the patient can firmly grasp handgrip.
- Have patient move limb through the range of motion while repositioning the chair.
- Lock the chair in place.

To minimize accessory and positioning changes when more than one shoulder test pattern is required, the following sequence is used. For each pattern the uninvolved side is tested first.

1. Abduction/Adduction

2. Extension/Flexion
3. Horizontal Abduction/Adduction
4. Internal/External Rotation in 90° Abduction
5. Internal/External Rotation in 90° Flexion
6. Internal/External Rotation Modified Neutral Position
7. Other Tests

Because of the repeated involvement of some muscles in each of the above patterns, a rest period is required between each test sequence. Two or three minutes is sufficient if only peak torque tests are performed. (This time is often used up while testing the contralateral limb, changing accessories and repositioning for the next movement pattern.) When a complete test sequence including "endurance" is performed, however, a three-minute rest period between testing each side and ten minutes or more between each movement pattern on the same side is recommended.

SHOULDER: ABDUCTION/ADDUCTION

Parts Needed

- Elbow/Shoulder Adapter
- Lumbar Cushion
- Footrest
-

Scale or Position	Scale or Position Setting	Right Limb Scale	Left Limb Scale
Chair Rotation Scale	80°	Black	Teal
Chair-Back Angle	65°		
Chair-Seat position	Up		
Dyna Tilt Scale	30°		
Dyna Height Scale	13		
Dyna Rotation Scale	10°	Teal	Black
Monorail Scale	32		

Reclining Chair Preparation

Chair-Back should be toward dynamometer.

- Install Footrest in chair receiving tube #2.

Dynamometer Preparation

- To install adapter on dyna input arm:
 1. Rotate long end of input arm to 12 o'clock.
 2. Insert Elbow/Shoulder Adapter into long end of input arm and secure.
 3. Secure handgrip at position A.
 4. Pull handgrip pin out so that the handgrip rotates freely. For testing, the handgrip should rotate freely. *For rehab, the resistance may be adjusted by tightening or loosening the knob.*

Position Patient

- Position patient appropriately on chair:
 1. Rotate Crank to adjust chair-back to meet patient's back.
 2. Provide Lumbar Cushion (as indicated.)
 3. Secure Seat Belt and Shoulder Belts.
- Monorail Scale: Move and secure chair at position 32. The patient should be able to comfortably grasp Elbow/Shoulder Adapter's handgrip when arm is fully abducted in front of face.
- Adjust dyna height and adapter length to accommodate patient's compromised axis of rotation to dyna axis. Adjust adapter length with patient's arm at 90° of abduction.

- Test patient's ROM. Adjust set-up if required. *Adjust the adapter length, monorail position and the Chair-Seat Fore/Aft position if necessary. There should be sufficient clearance between the Chair-Back cover and adapter arm so that there is no interference through the entire range of motion.*
- Record all scale values and click OK.



Figure 3-7 Shoulder: Abduction/Adduction.

The instantaneous axis of rotation changes throughout the movement. The compromise axis is medial to the acromion process when the limb is in the neutral position.

Pattern begins in Full Adduction

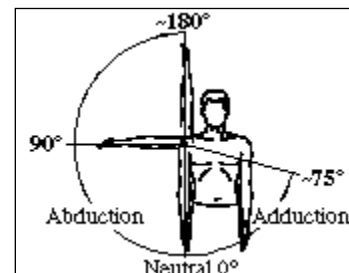

Before Conducting the Session

1. Check that all clamps and knobs are secure.
2. Check that the mechanical ROM stops are properly positioned according to the patient's range of motion, and that they are secure, before conducting the session.

SHOULDER: EXTENSION/FLEXION

Parts Needed

- Elbow/Shoulder Adapter
- Footrest

Scale or Position	Scale or Position Setting	Right Limb Scale	Left Limb Scale
Chair Rotation Scale	30°	Black	Teal
Chair-Back Angle	0°		
Chair-Seat position	Flat		
Dyna Tilt Scale	0°		
Dyna Height Scale	10		
Dyna Rotation Scale	28°	Black	Teal
Monorail Scale	End		

Reclining Chair Preparation

- Refer to the chart above.

Dynamometer Preparation

- Install adapter on dyna input arm:
 1. Rotate long end of input arm to 12 o'clock.
 2. Insert Elbow/Shoulder Adapter into long end of input arm and secure.
 3. Secure handgrip rotation at EXT/FLX, noting right or left side, and position at C.

Position Patient

- Position patient appropriately on chair and fasten Seat Belt around pelvis.
- Install Footrest into chair receiving tube #2.
- Chair-Seat Fore/Aft position: Move and secure chair at an appropriate position to properly align axis of rotation with dyna axis. Helpful hint: if you unlock the Fore/Aft translation while you lead the patient through the range of motion, the bed will be free to translate and self-align the patient.
- Test patient's ROM. Adjust set-up if required.
- Record all scale settings and click OK.

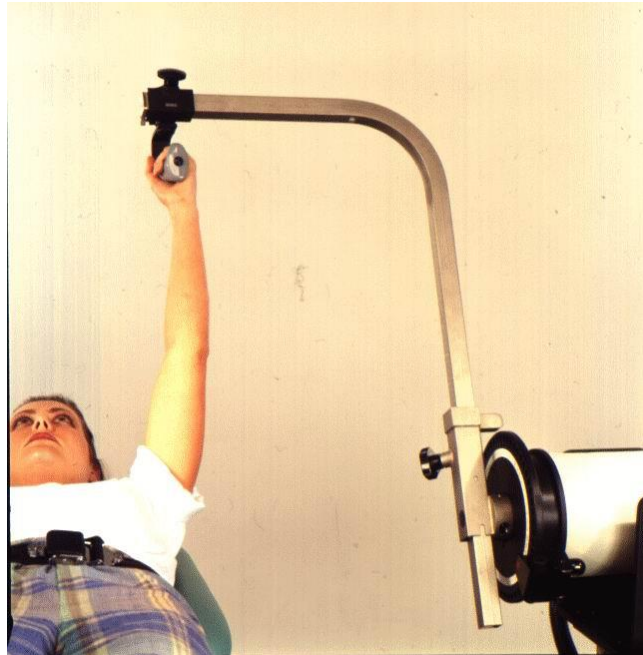
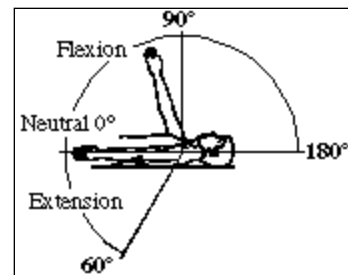

Figure 3-8 Shoulder: Extension/Flexion.

The instantaneous axis of rotation changes throughout the movement. The compromise axis is medial to the acromion process when the limb is in the neutral position.

Pattern Begins in Full Flexion



Before Conducting the Session

1. Check that all clamps and knobs are secure.
2. Check that the mechanical ROM stops are properly positioned according to the patient's range of motion, and that they are secure, before conducting the session.

SHOULDER: HORIZONTAL ABDUCTION/ADDUCTION

Parts Needed

- Elbow/Shoulder Adapter
- Torso Belt
- Footrest
-

Scale or Position	Scale or Position Setting	Right Limb Scale	Left Limb Scale
Chair-Back Translation	0		
Chair Rotation Scale	35°	Black	Teal
Chair-Back Angle	0°		
Chair-Seat position	Flat		
Dyna Tilt Scale	10°		
Dyna Height Scale	10		
Dyna Rotation Scale	55°	Black	Teal
Monorail Scale	39		

Reclining Chair Preparation

For this pattern, the patient's head rests on the Chair-Seat.

- Chair-Seat Fore/Aft Scale: Move and secure at position 6

Dynamometer Preparation

- Install adapter on dyna input arm:
 1. Insert Elbow/Shoulder Adapter into long end of input arm and secure.
 2. Secure handgrip rotation at **H-ABD/H-ADD** and position at **C**.

Position Patient

- Position patient appropriately on chair (with head at chair-seat) and fasten Seat Belt around chest.
- Test patient's ROM. Adjust set-up if required.
- Record all scale values and click OK.

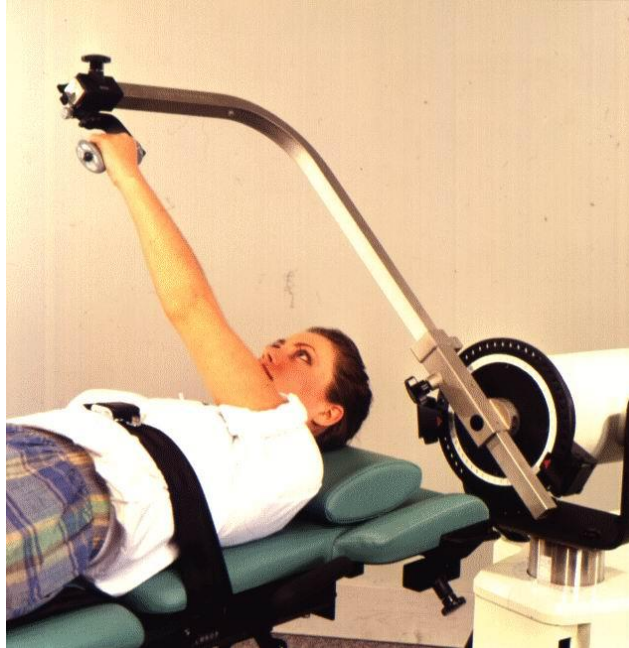
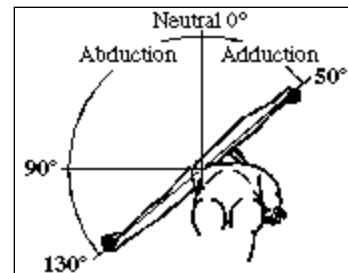

Figure 3-9 Shoulder: Horizontal Abduction/Adduction.

The instantaneous axis of rotation changes throughout the movement. The compromise axis is medial to the acromion process when the limb is in 90° horizontal abduction.

Pattern Begins in Full Adduction



Before Conducting the Session

1. Check that all clamps and knobs are secure.
2. Check that the mechanical ROM stops are properly positioned according to the patient's range of motion, and that they are secure, before conducting the session.

PNF D1: FLEXION-ADDUCTION/EXTENSION-ABDUCTION

Parts Needed

- Elbow/Shoulder Adapter
- Footrest

Scale or Position	Scale or Position Setting	Right Limb Scale	Left Limb Scale
Chair Rotation Scale	60°	Black	Teal
Chair-Back Angle	0°		
Chair-Seat position	Flat		
Dyna Tilt Scale	0°		
Dyna Height Scale	-		
Dyna Rotation Scale	30°	Black	Teal
Monorail Scale	-		

Reclining Chair Preparation

- Refer to the cart above.

Dynamometer Preparation

- To install adapter on dyna input arm:
 1. Insert Elbow/Shoulder Adapter into long end of input arm and secure.
 2. Secure handgrip rotation at **H-ABD/H-ADD** and position at **A**.
 3. To allow handgrip rotation, release rotation locking pin and adjust tension knob for desired resistance.

Position Patient

- Position patient on chair and stabilize as appropriate.
- Install Footrest into chair receiving tube #2.
- Monorail Scale: Move and secure chair at an appropriate distance from dyna to properly align patient's compromised axis of rotation with the dyna input arm.
- Test patient's ROM. Adjust set-up if required. (Adjust monorail position and Chair-Seat fore/aft position as required to accommodate patient's alignment.)
- Record all scale values and click OK.

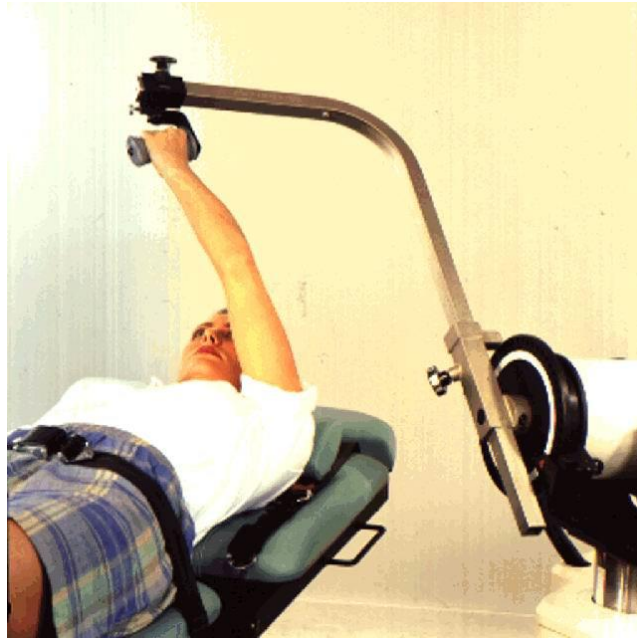
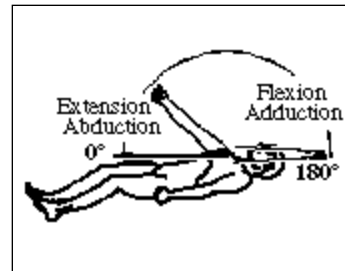

Figure 3-10 PNF D1: Flexion-Adduction/Extension-Abduction.

The instantaneous axis of rotation changes throughout the movement. The compromise axis is medial to the acromion process when the limb is in the neutral position.

The motion for this pattern begins in full Extension-Abduction and moves to full Flexion-Adduction. In order to attain full Extension-Abduction, the limb should be supinated and externally rotated.



Pattern begins in Full Extension-Abduction

Before Conducting the Session

1. Check that all clamps and knobs are secure.
2. Check that the mechanical ROM stops are properly positioned according to the patient's range of motion, and that they are secure, before conducting the session.

PNF D2: FLEXION-ABDUCTION/EXTENSION-ADDUCTION

Parts Needed

- Elbow/Shoulder Adapter
- Torso Stabilizer Belt
- Footrest
-

Scale or Position	Scale or Position Setting	Right Limb Scale	Left Limb Scale
Chair Rotation Scale	60°	Black	Teal
Chair-Back Angle	0°		
Chair-Seat position	Flat		
Dyna Tilt Scale	5°		
Dyna Height Scale	-		
Dyna Rotation Scale	25°	Black	Teal
Monorail Scale	-		

Reclining Chair Preparation

- Refer to chart above.

Dynamometer Preparation

- To install adapter on dyna input arm:
 1. Insert Elbow/Shoulder Adapter into long end of input arm and secure.
 2. Secure handgrip rotation at H-ABD/H-ADD and position at F.
 3. To allow handgrip rotation, release rotation locking pin and adjust tension knob for desired resistance.

Position Patient

- Position patient on chair and stabilize appropriately.
- (Optional) Secure Torso Belt.
- Install Footrest into chair receiving tube #2.
- Monorail Scale: Move and secure chair at an appropriate distance from dyna to properly align patient's compromised axis of rotation with dyna input arm.
- Test patient's ROM. Adjust set-up if required.
- Record all scale values and click OK.

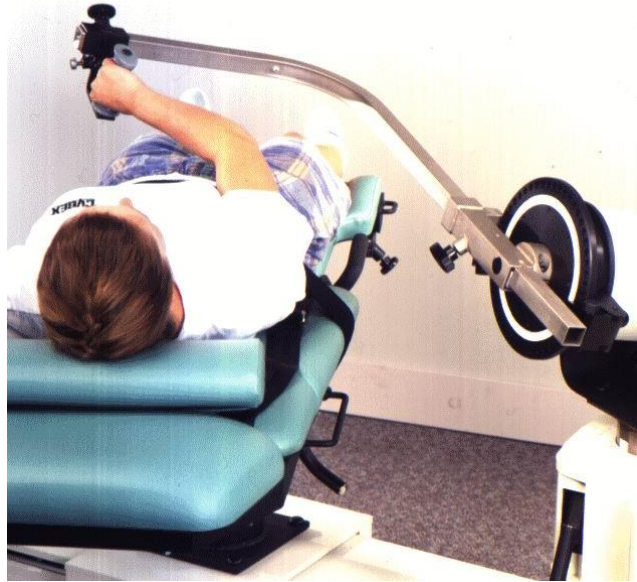
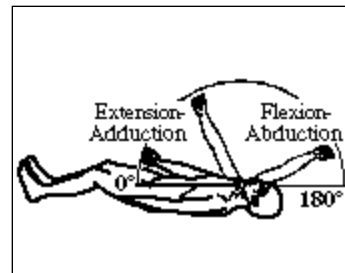

Figure 3-11 PNF D2: Flexion-Abduction/Extension-Adduction.

The instantaneous axis of rotation changes throughout the movement. The compromise axis is medial to the acromion process when the limb is in the neutral position.

The motion for this pattern begins in full Extension-Adduction and moves to full Flexion-Abduction. In order to attain full Extension-Adduction, the limb should be pronated and internally rotated.



Pattern Begins in Full Extension-Adduction

Before Conducting the Session

1. Check that all clamps and knobs are secure.
2. Check that the mechanical ROM stops are properly positioned according to the patient's range of motion, and that they are secure, before conducting the session.

SHOULDER: INTERNAL/EXTERNAL ROTATION IN 90° ABDUCTION

Parts Needed

- Wrist / Shoulder Adapter
- Elbow Stabilizer Pad
- Torso Belt
- Footrest

Scale or Position	Scale or Position Setting	Right Limb Scale	Left Limb Scale
Chair Rotation Scale	37°	Black	Teal
Chair-Back Angle	0°		
Chair-Seat position	Flat		
Dyna Tilt Scale	0°		
Dyna Height Scale	5		
Dyna Rotation Scale	37°	Black	Teal
Monorail Scale	57		

Reclining Chair Preparation

- Install Footrest in chair receiving tube #2.

Dynamometer Preparation

- To install Wrist/Shoulder adapter on dyna input arm:
 1. If the Counterbalance weight is on the Wrist/Shoulder Adapter, remove it.
 2. Insert Wrist/Shoulder Adapter into long end of input arm and secure.
 3. Secure handgrip at shoulder position 109.
 4. Secure Elbow Stabilizer Pad on short end of input arm.

Position Patient

- Position patient appropriately on chair.
- Secure Torso Belt.
- Chair-Seat Fore/Aft position: Move and secure chair at an appropriate position to align patient's axis of rotation with the dyna input arm.
- Strap patient's forearm in Elbow Stabilizer Pad.
- Test patient's ROM. Adjust set-up if required.
- Record all scale values then click OK.

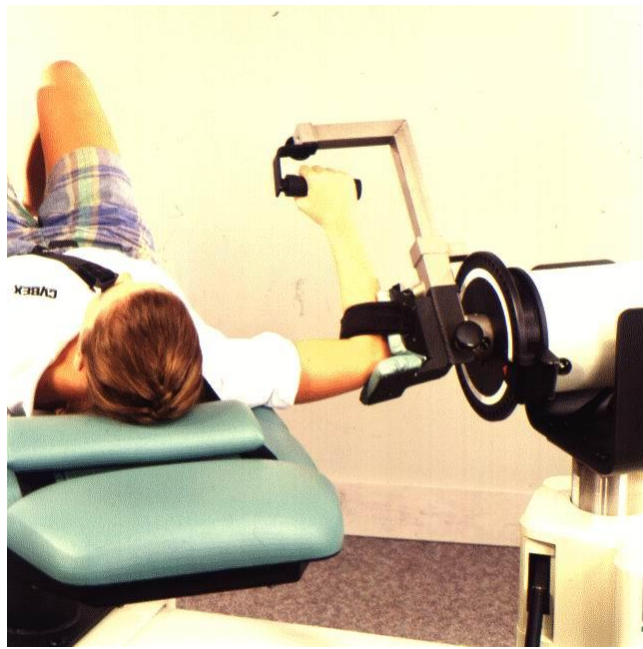
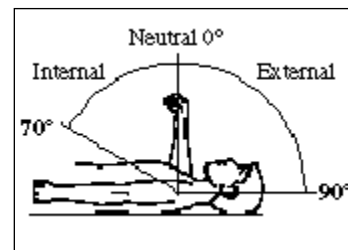

Figure 3-12 Shoulder: Internal/External Rotation in 90° Abduction.

The axis of rotation for Shoulder Internal/External Rotation patterns is the longitudinal axis of the humerus.



Pattern Begins in Full External Rotation

Before Conducting the Session

1. Check that all clamps and knobs are secure.
2. Check that the mechanical ROM stops are properly positioned according to the patient's range of motion, and that they are secure, before conducting the session.

SHOULDER: INTERNAL/EXTERNAL ROTATION (MODIFIED NEUTRAL POSITION - STANDING)

Parts Needed

- Wrist / Shoulder Adapter
- Elbow Stabilizer Pad

Scale or Position	Scale or Position Setting	Right Limb Scale	Left Limb Scale
Chair Rotation Scale	0°		
Chair-Back Angle	-		
Chair-Seat position	-		
Dyna Tilt Scale	70°		
Dyna Height Scale	-		
Dyna Rotation Scale	30°	Black	Teal
Monorail Scale	End		

Reclining Chair Preparation

- Move chair to extreme End of monorail.

Dynamometer Preparation

- To install the Wrist/Shoulder Adapter on dyna input arm:
 1. If the Counterbalance weight is on the Wrist/Shoulder Adapter, remove it.
 2. Insert Wrist/Shoulder Adapter into long end of input arm.
 3. Secure handgrip at shoulder position 110.
 4. Install Elbow Stabilizer Pad on short end of input arm and secure.

Position Patient

- Patient stands on monorail deck. To lock hips, have patient stand with opposite leg slightly forward and hand resting on thigh.
- Adjust dyna height to position patient's test arm with elbow flexed to 90° and shoulder slightly abducted. See Axis of Rotation. Stabilize forearm in Elbow Stabilizer Pad.
- Test patient's ROM. Adjust set-up if required.
- Record all scale values and click OK.



Figure 3-13 Shoulder: Internal/External Rotation, Mod - Standing.

The axis of rotation for Shoulder Internal/External Rotation patterns is the longitudinal axis of the humerus.

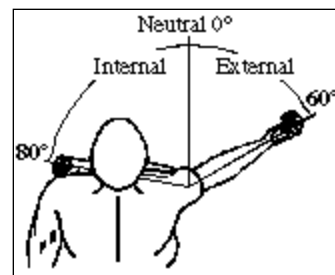

Pattern begins in Full External Rotation

Before Conducting the Session

1. Check that all clamps and knobs are secure.
2. Check that the mechanical ROM stops are properly positioned according to the patient's range of motion, and that they are secure, before conducting the session.

SHOULDER: INTERNAL/EXTERNAL ROTATION, MOD - SEATED)

Parts Needed

- Wrist / Shoulder Adapter
- Elbow Stabilizer Pad
- Lumbar Cushion

Scale or Position	Scale or Position Setting	Right Limb Scale	Left Limb Scale
Chair Rotation Scale	35°	Teal	Black
Chair-Back Angle	85°		
Chair-Seat position	Flat		
Dyna Tilt Scale	45°		
Dyna Height Scale	-		
Dyna Rotation Scale	5°	Black	Teal
Monorail Scale	-		

Reclining Chair Preparation

- See the chart above.

Dynamometer Preparation

- Dyna Height Scale: Adjust to patient axis.
- To install Wrist/Shoulder Adapter on dyna input arm:
 1. If the Counterbalance weight is on the Wrist/Shoulder Adapter, remove it.
 2. Insert Wrist/Shoulder Adapter into long end of input arm.
 3. Secure handgrip at shoulder position 110.
 4. Install Elbow Stabilizer Pad on short end of input arm and secure.

Position Patient

- Position patient appropriately on chair; fasten seat belt and provide Lumbar Cushion as indicated.
- Monorail Scale: Move and secure chair at an appropriate distance from the dyna to permit patient to comfortably grasp adapter handgrip.
- Position patient's test arm with elbow flexed to 90° and shoulder slightly abducted. Stabilize forearm in Elbow Stabilizer Pad.
- Test patient's ROM. Adjust set-up if required.
- Record all scale values, then click OK.



Figure 3-14 Shoulder: Internal/External Rotation, Mod - Seated.

The axis of rotation for Shoulder Internal/External Rotation patterns is the longitudinal axis of the humerus.

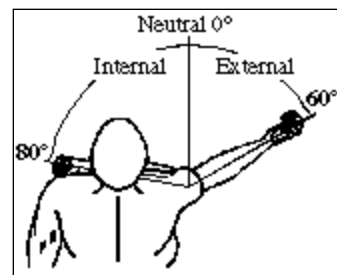

Pattern Begins in Full External Rotation

Before Conducting the Session

1. Check that all clamps and knobs are secure.
2. Check that the mechanical ROM stops are properly positioned according to the patient's range of motion, and that they are secure, before conducting the session.

SHOULDER: INTERNAL/EXTERNAL ROTATION IN 90 DEG FLEXION

Parts Needed

- Wrist / Shoulder Adapter
- Elbow Stabilizer Pad

Scale or Position	Setting	Right	Left
Chair Rotation Scale	70°	Teal	Black
Chair-Back Angle	85°		
Chair-Seat position	Flat		
Dyna Tilt Scale	20°		
Dyna Height Scale	21		
Dyna Rotation Scale	15°	Black	Teal
Monorail Scale	28		

Reclining Chair Preparation

- Refer to the chart above.

Dynamometer Preparation

- Install adapter on dyna input arm:
 1. If the Counterbalance weight is on the Wrist/Shoulder Adapter, remove it.
 2. Insert Wrist/Shoulder Adapter into long end of input arm.
 3. Secure handgrip at shoulder position **111**.
 4. Install Elbow Stabilizer Pad on short end of input arm and secure.

Position Patient

- Position patient appropriately on chair; fasten seat belt and adjust Lumbar Cushion.
- Adjust dyna height to position patient's test arm with elbow flexed to 90° and forearm parallel to adapter. Stabilize forearm in Elbow Stabilizer Pad.
- Chair-Seat Fore/Aft position: Move and secure chair at an appropriate distance from the dyna to permit patient to comfortably grasp adapter handgrip.
- Test patient's ROM. Adjust set-up if required.
- Record all scale settings and click OK.



Figure 3-15 Shoulder: Internal/External Rotation in 90° Flexion.

The axis of rotation is the longitudinal axis of the humerus.

If the length adjustment of the wrist/shoulder adapter is correct and the elbow flexed at 90° with the forearm parallel to the input arm, the axis alignment will be established and maintained by the Elbow Stabilization Pad.

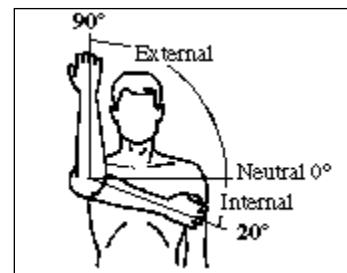

Pattern Begins in Full External Rotation

Before Conducting the Session

1. Check that all clamps and knobs are secure.
2. Check that the mechanical ROM stops are properly positioned according to the patient's range of motion, and that they are secure, before conducting the session.

TESTING AND EXERCISE OF THE WRIST AND FOREARM

Biomechanical Considerations

If isolated from the articulations of the wrist, the forearm has one degree of longitudinal freedom of movement. This is permitted by the proximal and distal articulations of the radius and ulna (radio-ulnar joints) which allow the radius to rotate, carrying the attached wrist and hand to the palm-down or palm up position (pronation or supination respectively).

Motions of the wrist do not originate from a single articulation. The radius articulates with three of the carpal bones (radiocarpal joint) which in turn articulate with each other, and the second row of carpal bones (intercarpal joints). This configuration allows the wrist to extend, flex, radially and ulnarly deviate, and to circumduct by combining these motions in a circular movement.

Except for the biceps and brachioradialis, all of the muscles controlling movements of the forearm, wrist and major finger movements lie within the forearm. The forearm stabilization V-pad and strap are designed specifically to stabilize securely without restricting movement or causing discomfort.

For the wrist extension/flexion pattern, the supinated forearm should be placed in the V-pad so that the distal forearm and wrist are maximally stabilized without interfering with movement. patients should be instructed to prevent elbow movement or rocking the forearm back and forth, both of which add forces to wrist movements. When testing forearm pronation/supination and wrist radial/ulnar deviation, the neutral positioned forearm should be placed in the forearm stabilization V-pad so that the elbow and upper forearm are immobilized as much as possible. patients should be instructed to keep the elbow locked. Because of the mobility of the wrist and difficulty in completely stabilizing the forearm, it is possible to circumduct the wrist in one direction or the other to add to pronation and supination movements. This combined motion should be encouraged during rehabilitation exercise but prevented during testing because it is not readily identifiable and reproducible.

In all cases, the V-pad strap should be as tight as the patient can comfortably tolerate and the elbow should be held flexed to 90°. Having the patient use the opposite hand for additional stabilization is helpful and seems to aid concentration on the correct movement pattern.

TESTING AND EXERCISE OF THE ELBOW

Biomechanical Considerations

The elbow is a comparatively simple hinge-type joint capable of four distinct movements. The humerus articulates with the ulna and radius permitting pronation and supination of the forearm (see Forearm: Pronation/Supination) while extension/flexion is accomplished through use of four principal elbow flexors and one principal elbow extensor. Additionally, four potential elbow flexors are called into play when simultaneous action or wrist stabilization is required. Because of the participation of the wrist and the powerful nature of maximal isokinetic contractions, all of these muscles are active in the elbow testing pattern described in this section.

The chair accessories and testing positions recommended in the set-up instructions are designed to minimize substitution of shoulder musculature in the movement pattern. Positioning the arm in 45° of abduction helps to eliminate the effects of shoulder elevation and depression that might occur during testing with the arm at the side of the body. The neutral positions of the shoulder relative to extension/flexion and the forearm relative to pronation/supination are easily established and provide excellent reproducibility. The elbow shoulder adapter allows reciprocal testing without placing the wrist at a disadvantage in either direction of movement. The axis of rotation for the elbow does change slightly throughout the range of motion for this pattern. However, the upholstery thickness compensates for this small difference and has little or no effect on test data.

Some individuals may be able to extend past anatomical zero in the course of elbow tests while others will not be able to reach this position. Because of this, the patient's full extension position may be identified with a goniometer or CSMI EDI 320, and set the starting position accordingly.

Shoulder girdle muscles must contract isometrically to stabilize the shoulder during maximum elbow extension/flexion. In the test position described, these actions should not significantly affect torque produced as long as the patient is not permitted to raise the shoulder or arm off the chair backrest. Most patients can perform this movement after proper instruction and a few practice repetitions. Use of range limiting may be necessary if excessive shoulder or arm movement cannot be controlled.

Because a number of elbow and flexor muscles are also important in movements of the forearm and wrist, testing of forearm pronation/supination and wrist extension/flexion is indicated for a thorough evaluation. These movements are also important in a rehabilitation program.

For rehabilitation purposes, the rotating handgrip can be used to combine actions of the forearm and wrist with elbow extension. This will make the movement more functional and enhance the functional nature of the exercise. Because it does not provide accurately reproducible positioning, the handgrip should be locked for testing of the elbow.

FOREARM: PRONATION/SUPINATION

Parts Needed

- Thigh/Forearm Stabilizer Tube
- Forearm Stabilizer V-Pad
- Wrist/Shoulder Adapter
- Counterbalance Weight (.8kg)
- Lumbar Cushion

Scale or Position	Scale or Position Setting	Right Limb Scale	Left Limb Scale
Chair Rotation Scale	80°	Teal	Black
Chair-Back Angle	90°		
Chair-Seat position	Flat		
Dyna Tilt Scale	0°		
Dyna Height Scale	28		
Dyna Rotation Scale	10°	Black	Teal
Monorail Scale	59		

Reclining Chair Preparation

CHAPTER 2 Install Forearm Stabilizer V-Pad on Thigh/Forearm Stabilizer Tube with tapered end forward.

Dynamometer Preparation

- To install adapter on dyna input arm:
 1. Screw Counterbalance weight on Wrist/Shoulder Adapter
 2. Install Wrist/Shoulder Adapter into short end of input arm and secure at PRO/SUP line.
 3. Secure adapter handle grip at 112 position.
 4. Rotate adapter so that handgrip is bottom up.

Position Patient

- Position patient appropriately on chair; provide Lumbar Cushion as indicated.
- Rotate Crank to adjust chair-back to meet patient's back.
 1. Secure Seat Belt.
 2. Insert Thigh/Forearm Stabilizer Tube into chair receiving tube #2.
- Adjust dyna height and Thigh/Forearm Stabilizer Tube height to attain 90° elbow flexion.
- Chair-Seat Fore/Aft position: Move and secure at an appropriate position such that patient's wrist is just distal to end of V-pad. Stabilize patient's forearm in V-pad.
- Test patient's ROM. Adjust set-up if required. Record all scale values, then click OK.

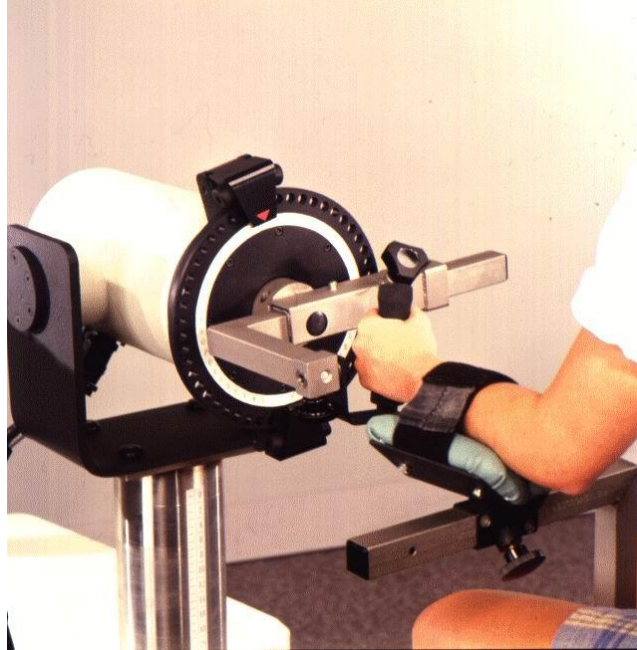
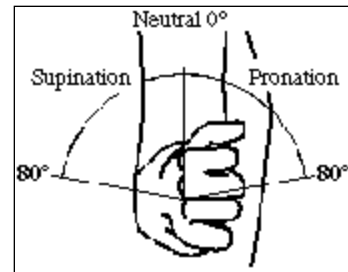

Figure 3-16 Forearm: Pronation/Supination

The axis of rotation bisects the head of the ulna distally and the head of the radius proximally. It is established by placing the forearm directly in line with the dot on the dynamometer input tube at approximately the level of the ring finger.



Session Begins in Full Supination

Before Conducting the Session

1. Check that all clamps and knobs are secure.
2. Check that the mechanical ROM stops are properly positioned according to the patient's range of motion, and that they are secure, before conducting the session.

WRIST: EXTENSION/FLEXION

Parts Needed

- Thigh/Forearm Stabilizer Tube
- Forearm Stabilizer V-Pad
- Wrist/Shoulder Adapter
- Lumbar Cushion

Scale or Position	Scale or Position Setting	Right Limb Scale	Left Limb Scale
Chair Rotation Scale	40°	Teal	Black
Chair-Back Angle	90°		
Chair-Seat position	Flat		
Dyna Tilt Scale	0°		
Dyna Height Scale	27		
Dyna Rotation Scale	35°	Teal	Black
Monorail Scale	32		

Reclining Chair Preparation

- Install Forearm Stabilizer V-Pad on Thigh/Forearm Stabilizer Tube with tapered end forward.

Dynamometer Preparation

- Install Wrist/Shoulder adapter on dyna input arm:
 1. If the Counterbalance weight is on the Wrist/Shoulder Adapter, remove it.
 2. Install Wrist/Shoulder Adapter into short end of Dyna Input Tube and secure.
 3. Rotate adapter handgrip to **113** position and secure.

Position Patient

- How to position patient appropriately on chair:
 1. Rotate Crank to adjust chair-back to meet patient's back. Provide Lumbar Cushion if indicated.
 2. Secure Seat Belt.
- Insert Thigh/Forearm Stabilizer Tube into chair receiving tube #2.
- Adjust dyna height and Thigh/Forearm Stabilizer Tube height to attain 90° elbow flexion.
- Chair-Seat Fore/Aft position: Move and secure at an appropriate position such that patient's wrist is just distal to end of V-pad. Strap patient's forearm in V-pad.
- Test patient's ROM. Adjust set-up if required.
- Record all scale values, then click OK.

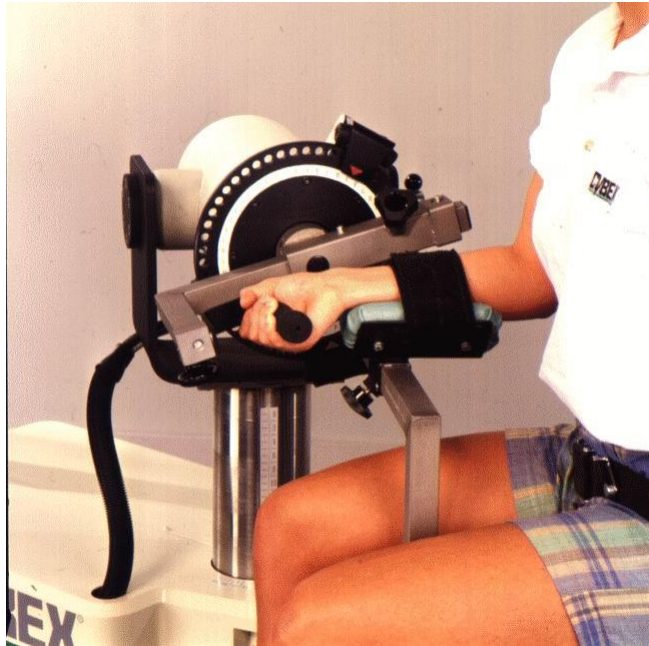
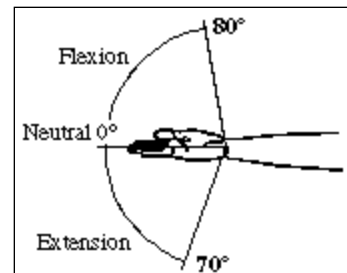

Figure 3-17 Wrist: Extension/Flexion

This axis alignment is critical and somewhat difficult in the pattern. The axis of rotation is slightly oblique passing through the wrist just distal to the tubercle of the radius and the head of the ulna (approximately where the hand meets the wrist).



Pattern Begins in Full Flexion

Before Conducting the Session

1. Check that all clamps and knobs are secure.
2. Check that the mechanical ROM stops are properly positioned according to the patient's range of motion, and that they are secure, before conducting the session.

WRIST: RADIAL/ULNAR DEVIATION

Parts Needed

- Thigh/Forearm Stabilizer Tube
- Forearm Stabilizer V-Pad
- Wrist/Shoulder Adapter
- Lumbar Cushion

Scale or Position	Scale or Position Setting	Right Limb Scale	Left Limb Scale
Chair-Back Translation	0		
Chair Rotation Scale	35°	Black	Teal
Chair-Back Angle	0°		
Chair-Seat position	Flat		
Dyna Tilt Scale	10°		
Dyna Height Scale	10		
Dyna Rotation Scale	55°	Black	Teal
Monorail Scale	39		

Reclining Chair Preparation

- Install Forearm Stabilizer V-Pad on Thigh/Forearm Stabilizer Tube with tapered end forward.

Dynamometer Preparation

- Install Wrist/Shoulder Adapter on dyna input arm:
 1. If the Counterbalance weight is on the Wrist/Shoulder Adapter, remove it.
 2. Install Wrist/Shoulder Adapter into short end of input arm and secure.
 3. Rotate adapter handgrip to **114** position and secure.

Position Patient

- Position patient appropriately on chair; provide Lumbar Cushion (if indicated.)
 1. Rotate Crank to adjust chair-back to meet patient's back. Provide Lumbar Cushion if indicated.
 2. Secure Seat Belt.
- Insert Thigh/Forearm Stabilizer Tube into chair receiving tube #2.
- Adjust dyna height and Thigh/Forearm Stabilizer Tube height to attain 90° elbow flexion.
- Chair/Seat Fore/Aft position: Move and secure at an appropriate distance such that patient's wrist is just distal to end of V-pad. Strap patient's forearm in V-pad.
- Test patient's ROM. Adjust set-up if required.
- Record all scale values, then click OK.

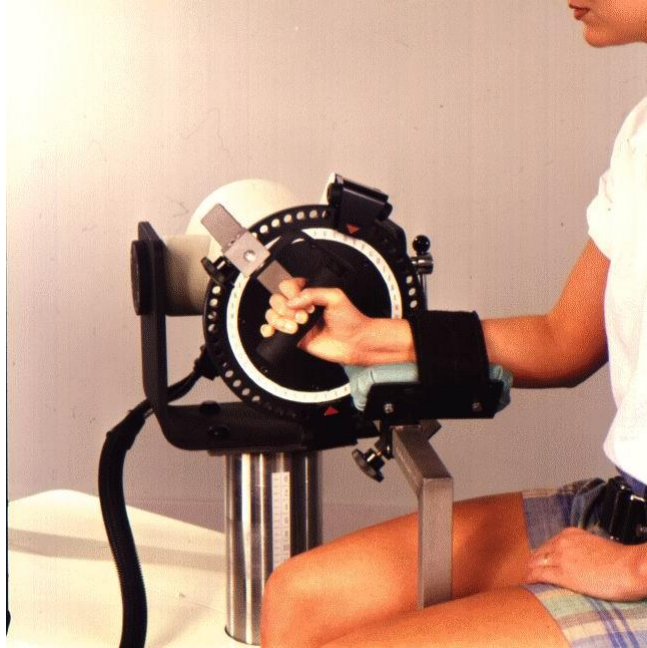
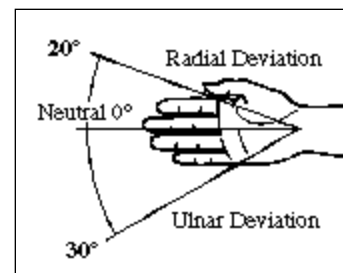

Figure 3-18 Wrist: Radial/Ulnar Deviation

The axis of rotation is located approximately at the center of the capitate bone. This is found at the middle of the wrist just distal to the axis for extension/flexion.



Pattern Begins in Full Ulnar Deviation

Before Conducting the Session

1. Check that all clamps and knobs are secure.
2. Check that the mechanical ROM stops are properly positioned according to the patient's range of motion, and that they are secure, before conducting the session.

ELBOW: EXTENSION/FLEXION

Parts Needed

- Elbow/Shoulder Adapter
- Lumbar Cushion
- Footrest

Scale or Position	Scale or Position Setting	Right Limb Scale	Left Limb Scale
Chair-Back Translation	0		
Chair Rotation Scale	35°	Black	Teal
Chair-Back Angle	0°		
Chair-Seat position	Flat		
Dyna Tilt Scale	10°		
Dyna Height Scale	10		
Dyna Rotation Scale	55°	Black	Teal
Monorail Scale	39		

Reclining Chair Preparation

- Refer to chart above.

Dynamometer Preparation

- To install adapter on dyna input arm:
 1. Install Elbow/Shoulder Adapter into long end of input arm and secure.
 2. Secure handgrip rotation at EXT/FLX, noting right or left side, and position at I (letter i).

Position Patient

- Install Footrest in chair receiving tube #2.
- Position patient appropriately on chair and fasten seat belt around pelvis. Secure contralateral Shoulder Belt across torso.
- Raise dyna and adjust length of Elbow/Shoulder Adapter to properly align the patient's axis of rotation with the dyna's axis.
- Chair-Seat Fore/Aft position: Move and secure at an appropriate distance from the dyna to properly align patient's axis of rotation with the dyna's axis.
- Test patient's ROM. Adjust set-up if required.
- Record all scale values, then click OK.

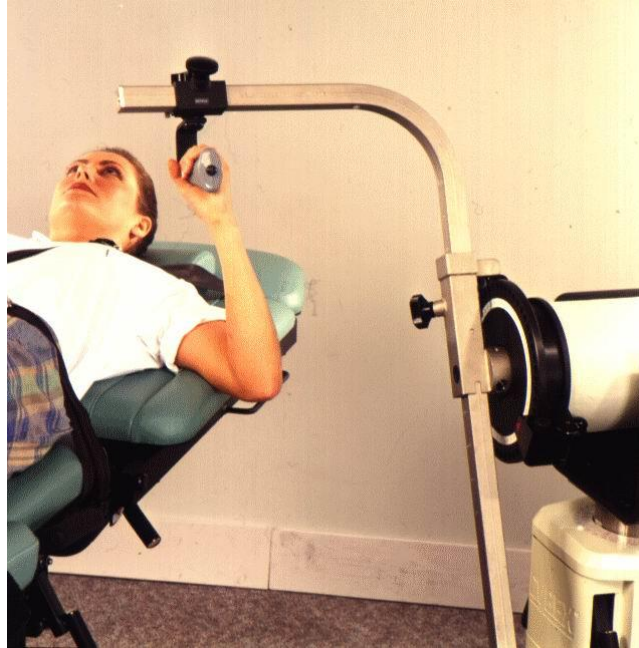
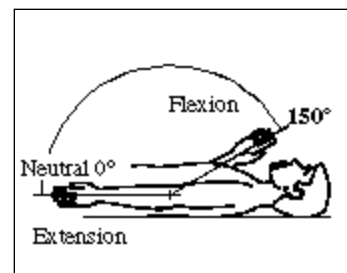

Figure 3-19 Elbow: Extension/Flexion.

The axis of rotation is immediately distal to the lateral epicondyle and moves only slightly anteriorly as flexion increases.



Pattern Begins in Full Flexion

Before Conducting the Session

1. Check that all clamps and knobs are secure.
2. Check that the mechanical ROM stops are properly positioned according to the patient's range of motion, and that they are secure, before conducting the session.

TESTING AND EXERCISE OF THE HIP

Biomechanical Considerations

Like the shoulder, the hip has three degrees of freedom of movement. Unlike the shoulder complex, however, the pelvic girdle is bound so tightly by its articular structure and connective tissues that it has virtually no intrinsic movement. Furthermore, the articular surfaces of the hip joint (head of femur and acetabulum) are large and compare favorably to one another with a tight joint capsule and strong ligamentous attachments. Thus, the hip has much greater stability and correspondingly less mobility than the shoulder.

This usually stable configuration reduces the possible contraindications through the full range movement. Pelvic contributions to range of motion (posterior tilt in flexion, lateral tilt in abduction) are limited and identifiable. Reference point structures of the hip (greater trochanter, iliac spines) are, in most cases, readily palpated. Due to these factors, the axis of rotation for testing can be quickly established and most patients tested without limiting range of motion. If necessary, the range of motion stops can be used to limit undesirable movement.

The actions and interactions of the hip musculature are complex. Any functional movement requires coordinated, synchronous contractions of many muscles. A number of major muscles participate in two or even three movement patterns. The function of some muscles change completely depending on joint position and whether or not movement occurs while weight bearing. Although these present no testing difficulties (except as previously noted for adduction), basic knowledge of kinesiological factors is particularly helpful when evaluating hip trauma or pathology.

Proper stabilization is imperative when testing the hip. For all patterns, the pelvis and torso must be prevented from adding extraneous motion through the use of the seat belt and torso stabilization strap. For abduction/adduction testing the contralateral limb must also be stabilized. Both abduction/adduction and extension/flexion require use of the thigh stabilization pad. Always place the thigh pad just proximal to the knee.

HIP: ABDUCTION/ADDUCTION

Parts Needed

- Knee/Hip Adapter
- Torso Belt
- Knee/Hip Pad

Scale or Position	Scale or Position Setting	Right Limb Scale	Left Limb Scale
Chair-Back Translation	0		
Chair Rotation Scale	0°		
Chair-Back Angle	0°		
Chair-Seat position	Flat		
Dyna Tilt Scale	0°		
Dyna Height Scale	23		
Dyna Rotation Scale	0°		
Monorail Scale	0		

Reclining Chair Preparation

- Chair-Seat Fore/Aft Scale: **25**.

Dynamometer Preparation

- To install adapter on dyna input arm:
 1. Install Knee/Hip Pad on Knee/Hip Adapter.
 2. Insert adapter into long end of dyna input arm tube and secure.

Position Patient

- Position patient on chair and stabilize appropriately.

Optional - the Thigh Stabilizer Strap can be used to stabilize the opposite limb.

- Secure Torso Belt.
- Chair-Seat Fore/Aft position: Move and secure chair at an appropriate distance from dyna to properly align patient's axis of rotation with dyna axis.
- Position Knee/Hip Pad on patient's leg and secure.
- Test patient's ROM. Adjust set-up if required.
- Record all scale values, then click OK.



Figure 3-20 Hip: Abduction/Adduction.

The axis of rotation is superior and medial to the greater trochanter.

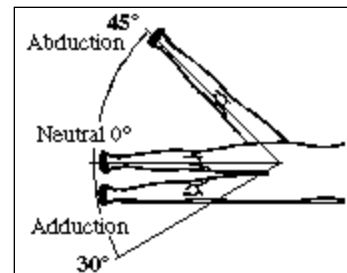

Session Begins in Full Adduction

Before Conducting the Session

1. Check that all clamps and knobs are secure.
2. Check that the mechanical ROM stops are properly positioned according to the patient's range of motion, and that they are secure, before conducting the session.

HIP: FLEXION/EXTENSION

Parts Needed

- Knee/Hip Adapter
- Footrest
- Knee/Hip Pad
- Torso Belt

Scale or Position	Scale or Position Setting	Right Limb Scale	Left Limb Scale
Chair-Back Translation	0		
Chair Rotation Scale	0°		
Chair-Back Angle	0°		
Chair-Seat position	Flat		
Dyna Tilt Scale	0°		
Dyna Height Scale	9		
Dyna Rotation Scale	0°		
Monorail Scale	7		

Reclining Chair Preparation

- Chair-Seat Fore/Aft Scale: 25.
- Install footrest into chair receiving tube #2.

Dynamometer Preparation

- To install adapter on dyna input arm:
 1. Install Knee/Hip Pad on Knee/Hip Adapter.
 2. Insert adapter into long end of dyna input arm tube and secure.

Position Patient

- Position patient on chair and stabilize appropriately.
- Secure Torso Belt.
- Chair-Seat Fore/Aft Position: Move and secure chair at an appropriate distance from dyna to properly align patient's axis of rotation with dyna axis.
- Position Knee/Hip Pad on patient's leg and secure.
- Test patient's ROM. Adjust set-up if required.
- Record all scale values then click OK.



Figure 3-21 Hip: Flexion/Extension.

The axis of rotation is slightly anterior in extreme flexion as the pelvis tilts to increase range of motion. The normal movement synergy does not affect testing accuracy.

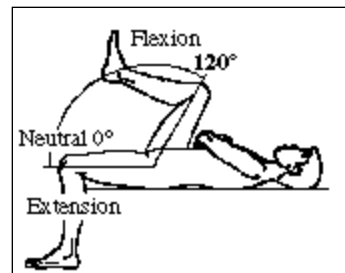

Pattern Begins in Full Extension

Before Conducting the Session

1. Check that all clamps and knobs are secure.
2. Check that the mechanical ROM stops are properly positioned according to the patient's range of motion, and that they are secure, before conducting the session.

HIP: INTERNAL/EXTERNAL ROTATION

Parts Needed

- Ankle Adapter
- Footplate
- Torso Belt

Scale or Position	Setting	Right	Left
Chair-Back Translation	0		
Chair Rotation Scale	82°	Teal	Black
Chair-Back Angle	0°		
Chair-Seat position	Flat		
Dyna Tilt Scale	0°		
Dyna Height Scale	5		
Dyna Rotation Scale	10°	Black	Teal
Monorail Scale	End		

Reclining Chair Preparation

- Chair-Seat Fore/Aft Scale: 15
- Install footrest into chair receiving tube #3 for Right hip test and #1 for Left.

Dynamometer Preparation

- To install Ankle Adapter on dyna input arm:
 1. If Counterbalance weight is on Footplate, remove it.
 2. Install Ankle Adapter on Footplate; position for INT/EXT rotation.
 3. Rotate the long end of the dyna input arm to 12 o'clock position, then insert the Ankle Adapter up into the Short end of the input arm and secure.

Position Patient

- Position patient appropriately on chair and fasten Thigh Stabilizer Strap around involved leg.
- Secure Torso Belt.
- Chair-Seat Fore/Aft position: Move and secure chair at an appropriate distance from dyna to properly position patient's foot on Footplate.
- Secure foot on Footplate.
- Test patient's ROM. Adjust set-up if required.
- Record all scale values and click OK.

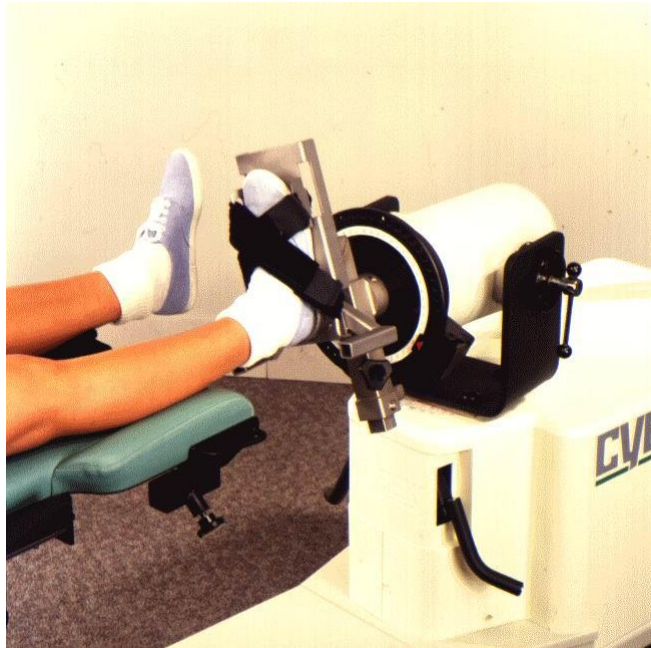
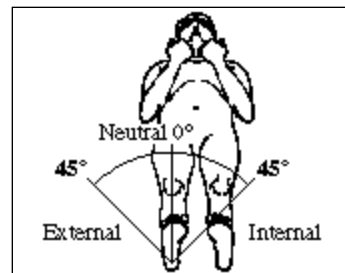

Figure 3-22 Hip: Internal/External Rotation.

The axis of rotation is a mechanical axis of the femur (line through centers of hip and knee joints). This can be visualized, approximated and then fine adjusted during warm up / familiarization repetitions.



Pattern Begins in Full External Rotation

Before Conducting the Session

1. Check that all clamps and knobs are secure.
2. Check that the mechanical ROM stops are properly positioned according to the patient's range of motion, and that they are secure, before conducting the session.

TESTING AND EXERCISE OF THE TRUNK

Biomechanical Considerations

Anatomical Structures

The anatomical structures of the spine can be divided into dynamic and static stabilizers. Those structures containing viscoelastic qualities which stabilize via dynamic force production may be considered dynamic. The dynamic stabilizers of the spine include those muscles responsible for extension, flexion, rotation and lateral flexion of the trunk as well as their tendinous attachments. Those structures in which the matrix is noncontractile and stabilization is through a relatively rigid mechanism may be considered static. Bony structures, the ligamentous system, joint surfaces and intervertebral discs make up the static stabilizers of the spine. The innervation of the muscles and joint structures provides input to and feedback from dynamic and static structures. In addition to the afferent (sensory) and efferent (motor) pathways, this system includes muscle spindles, Golgi tendon organs, Golgi-Mazzoni corpuscles, Pacinian corpuscles, Golgi ligament endings, free nerve endings and Ruffini endings which provide proprioceptive control. The dynamic, static and neurologic structures work in concert, providing a simultaneously rigid and elastic mechanism for control of trunk motion and stabilization.

Dynamic Control

Trunk extension is the result of a dynamic interaction of the hip and spine from a forward flexed position. The hip extensor musculature (the three hamstrings, gluteus maximus, and to a limited extent, the three adductors) is at a mechanically advantageous position early in the extension range of motion. As extension continues, the lever arm at the ischial tuberosity decreases and the hip extensors lose their mechanical advantage. The erector spinae (iliocostalis, longissimus, spinalis) and deep posterior muscles (transversospinalis, interspinalis, intertransversarii, levatores costarum) then gain advantage in completing the motion to full extension. Therefore, the order of recruitment in trunk extension is hamstrings, glutei and, finally, the paravertebral muscles. Execution of hyperextension continues the activity of primarily the paravertebral muscles and the gluteus maximus, particularly against resistance or gravity.

Trunk flexion also incorporates the combined movement of the hip and spine. The anterior trunk musculature includes the rectus abdominus, internal and external obliques, and transversus abdominus. The primary hip flexion musculature consists of the iliopsoas, tensor fascia latae, pectineus and rectus femoris. It should be noted that functional forward bending is primarily controlled by an eccentric contraction of the trunk extensor. However, trunk flexion against gravity or a resistance involves a powerful contraction of the abdominals and, depending on the position of the hip, the hip flexors.

During CSMI Trunk Extension/Flexion (TEF) testing and exercise, the musculature of both the hip and spine is worked. The standing position for the TEF Modular Component was adopted in order to gain maximal information about the combined hip/spine action from a functional posture. The significance of this interaction during trunk motion has been reported by various

researchers, Farfan* has demonstrated the importance of the gluteals and hamstrings in generating the force necessary to handle heavy loads. A primary role of the erectors, as outlined by Gracovetsky*, Farfan and Helleur* is to balance the anterior shearing forces on the vertebrae generated during lifting. Maintenance of intraabdominal pressure and tension abdominals on the thoracolumbar fascia are important functions of the abdominals, while the iliopsoas is essential for supporting lumbar lordosis and stabilizing the spine anteriorly. Additionally, Nachemson* has shown that a standing position elicits less intradiscal pressure than a sitting position.

Preliminary electromyographic (EMG) studies on the TEF Modular Component have indicated certain muscle firing patterns doing isokinetic loading. At the La Crosse* test site, EMG analysis of extension has shown recruitment patterns reflective of the normal hamstring, glutei, paravertebral extension sequence. In flexion, the firing sequence is less clear, in part due to the inaccessibility of the deep hip flexor musculature to EMG electrodes. Test site clinicians have noted that some individuals tend to execute flexion on the TEF Modular Component with more or less of a curling motion than others, which might account for more variable EMG data than in extension.

Static Stabilizers

The static stabilizers of the trunk include the vertebrae (7 cervical, 12 thoracic, 5 lumbar, the fused sacral segments, and the coccyx), ligaments, intervertebral discs and joint surfaces. Additionally, the vertebrae are influenced by their attachment to the rib cage, pelvis and indirectly, the shoulder girdle. Bony characteristics of individual vertebrae include the vertebral bodies, transverse and spinous processes, articular facets, foramen (vertebral canal) and, in thoracic vertebrae, rib articular facets. Vertebral bone is primarily trabecular, making it particularly susceptible to osteoporotic changes.

Structural range of motion is primarily restricted by the static stabilizers. Spinal range of motion in extension is approximately 25 to 30% less than in flexion, in part due to the posterior articular processes becoming increasingly interlocked. Also during extension, the disc is flattened posteriorly and expanded anteriorly. Trunk flexion involves compression of the anterior portions of the intervertebral discs and a gliding motion of the articular processes. Roentgenography has confirmed that the anticipated "true lumbar motion" from T12 to S1 is about 84°, assuming motion is equal in the six segments. In normal subjects, Mayer* has found a mean true lumbar motion of 82°, with 55° in flexion and 27° in extension. When combined with motion of the hip gross trunk flexion was 120° and trunk extension was 45°. The contribution of hip flexion and extension to total trunk range of motion is critical in assessing the patient's progress in this area.

Bony Structures

The vertebral bodies are of primary importance in the regulation of weight-bearing loads. As a unit, the three curve system of the spine ensures maximal efficiency for the distribution of compressive forces. Engineers have shown that the resistance of a curved column is directly proportional to the square of the number of curves plus one. As illustrated by the equation $R =$

$N^2 + 1$, where R is the amount of resistance and N is equal to the number of curves, a three curve arrangement results in a resistive force of 10. Taking out any one curve, such as in maintaining a pelvic tilt position, reduces that potential for resistance by half, as R is reduced to 5.

The facet joints are designed to guide and, with the assistance of the ligaments, restrict the segmental movement. The upper cervical facets, lying in the horizontal plane, are oriented to provide the most freedom in rotation. The facet surfaces of the lower cervical vertebrae become oblique and approach the frontal plane. This permits flexion, extension, hyperextension, and lateral flexion. In the thoracic area, the facets are in the frontal plane with rotation as the most unlimited motion. Lateral flexion is also unrestricted by the orientation of the facets; however, the attachment of the rib cage restricts this function. The lumbar facets lie in the sagittal plane which allows relative freedom of flexion, extension and hyperextension while severely restricting rotation. A small degree of rotation is possible in the lumbar spine due to approximation within the facet joints.

In the upright position, with the lumbar spine in about two degrees of extension, the facets normally carry a minimum amount of weight. In a normal resting posture, a nearly close-packed position of the facet joints is formed by the spinal curves. The facets are maintained in a loose-packed position in a pelvic tilt posture. Although this may relieve acute symptomatology, the spine is left in an unstable weight bearing position. In the loose-packed position, the normal biomechanical relationship of the segments is compromised and the lumbar spine's susceptibility to compressive forces is increased.

Ligamentous Characteristics

The ligamentous structure of the spine is designed to fulfill several functions. According to White* and Panjabi* the ligaments must allow adequate physiologic motion and fixed postural attitudes between vertebrae, with a minimum expenditure of muscle energy. They must also protect the spinal cord by restricting motion within well-defined limits, particularly in traumatic situations where high loads are applied at fast speeds. In addition, it has become clear that the ligaments play a significant role in providing the central nervous system with information in regard to posture and movement.

The spinal ligaments include the anterior and posterior longitudinal, supraspinous, interspinous, capsular, intertransverse and ligamentum flavum. According to Paris*, certain anatomical features of the ligamentous system have clinical significance which are sometimes overlooked. The interspinous ligament courses upward and backward, although it is commonly misrepresented as running upward and forward. This direction permits a large range of motion while still resisting excessive movement. In the lumbar region, certain muscles specifically augment the support of the ligaments. The supraspinous ligament most commonly ends at the L4 level, after which it is replaced by the interlocking fibers of the somewhat stronger erector spinae tendons of insertion. MacConniall* and Basmajian* have also described the transversospinalis muscles as dynamic posterior "ligaments of the lumbar region." Conversely, a

unique elastic quality characterizes the ligamentum flavum, which enables it to assist in regaining the upright position from forward bending. Damage to the ligamentum flavum during surgery may result in decreased proprioceptive stability of the joint.

Intervertebral Disc

The intervertebral disc has been the subject of a large body of research, testifying to its enigmatic and relatively complex nature. For the purposes of this documentation, clinical characteristics of the disc will be limited to those aspects specifically related to isokinetic trunk testing, particularly disc pressures.

A great deal of literature has been presented on the subject of intradiscal pressures and their relation to disc injury, primarily by Nachemson*. However, the functional relationship of these pressures as they relate to injury remains unclear. Gracovetsky* reports that during lifting, the transference of load occurs within 0.3 seconds with maximal stress applied in the first 0.1 seconds. Nachemson's recordings show that the rise in intradiscal pressure achieves its maximum approximately 1 second after a load is applied. Such findings suggest that the nucleus pulposus is not the important structure supporting the stress when weight is lifted. Rather, the primary support structure appears to be the annulus which responds to load bearing with a slow creep through the annular rings.

Because the adult discs possess no blood vessels, they belong to the group of "bradytrophic" tissues, which receive their nutrient substances by diffusion. The disc cells (fibroblasts, cartilaginous cells and chordal cells) have a biological half-life of only a few weeks and must be continually replaced. Therefore, a constant exchange of substances is necessary to guarantee an equilibrium between biosynthesis and lysis of structural elements. Fluid shifts due to intradiscal pressure are critical in promoting this substance exchange. A regular loading and unloading cycle promotes the exchange of substances and fluids in the disc, whereas maintenance of a constant position results in a slowing down of these pressure dependent shifts. Additionally, biochemical changes in the disc tissue have an effect on the biomechanics of the motion segment. An increase in the number of particles, particularly of molecules exercising osmotic pressure, results in enhancement of fluid inflow and a rise in swelling pressure. If the number of such particles decreases, loss of fluid and desiccation occur.

Isokinetic trunk testing is contraindicated for patients suffering from an acutely injured disc. However, gradually increasing the disc's response to load and pressure changes incorporates the application of Wolff's Law as it relates to soft tissue healing. Just as bone will remodel itself in accordance with the stress placed upon it, soft tissue will make similar adaptations. Critical to both bone and soft tissue is the rate at which these stresses are experienced. Experimental evidence also suggests there is a repair or adjustment mechanism in the disc which is mechanical in nature. Gracovetsky* notes the importance of the integration of muscular, ligamentous, and bony control in efficiently distributing loads throughout the spinal segments. Systematically increasing the resistive capacities of these elements is essential in returning the system to productive levels following injury.

Sacroiliac Joint

The sacroiliac joint is stabilized by its own unique ligamentous and bony support system. It is formed by the junction between the ala of the sacrum and auricular surface of the ilium. Although sometimes misconstrued as an immovable joint, the sacroiliac junction is a diarthrodial (movable), arthrodial (gliding) class and type of joint. The principal ligaments include the anterior sacroiliac, posterior sacroiliac, interosseous, and iliolumbar ligaments. Additionally, the sacrotuberous and sacrospinous ligaments anchor the sacrum to the tuberosity and spine of the ischium. Anomalies within the sacrum, such as partial or complete lumbarization or sacralization, may produce asymmetrical or unstable forces within the sacroiliac and lumbar areas. Such asymmetry or instability may render the joint vulnerable to abnormal wear patterns, increasing the stress on the supporting structures.

Neurologic Structures

It is an understatement to define the neurologic system as complex; however, a number of researchers have delineated its function in the spine. Of particular importance to the clinician is the relationship of these structures to pain in the patient. All of the structures of the lumbar spine, with the possible exception of the posterior dura, are innervated by at least two, and usually three segmental nerves. By establishing the specific distribution of the nerve supply to the lumbar spine, one also establishes possible sources of primary low-back pain.

Work conducted by Bogduk* has established the role of various structures in producing pain. The innervation of the intervertebral discs provides the anatomical substrate for primary disc pain. The natural cause of disc pain is not known but strain following excessive movement, or pain in response to degenerative disease are likely prospects. The dura is also a potential source of pain since it covers the nerve roots and is subject to the same mechanical and chemical processes that affect the roots. However, it is independent of pain caused by root compression, as the dura is innervated by the sinuvertebral nerves. Bogduk also postulates that the sinuvertebral nerves may transmit pain signals from engorgement of epidural veins. A similar mechanism involving the basivertebral veins probably underlies intraosseous hypertension, which is also a potential source of pain. Direct innervation of the apophysial joints make them potential pain producing structures related to a multitude of disorders.

The multiple segmental innervation of the spine gives rise to an extensive and variable distribution of referred pain. Paris* has discussed the common error of interpreting referred pain in relation to the cutaneous dermatomes. Pain from the nerve roots and other central structures refer into portions that do not necessarily correspond to the dermatomes. The work of Kellegren* and Mooney* and Robertson* specifically addresses the relationship of referred pain to various anatomical areas.

Paris* has also emphasized the importance of proprioceptive feedback in maintaining the functional integrity of the spine. In this way, the system may be thought of as providing neurologic stabilization. Extrapolating from work conducted on monkeys, investigators have postulated that the deep posterior muscles of the back in humans contain a high proportion of

muscle spindles. Such a feature underscores their potential role in relaying reflex activity. The importance of proprioceptive rehabilitation has long been accepted empirically by clinicians with regard to knee and ankle injuries. The contribution of these sensory feedback mechanisms in the spine may warrant equally attentive rehabilitative focus.

Comprehensive consideration of the static, dynamic and neurologic stabilizers of the trunk and their relationship to the rehabilitation will help the clinician better determine the nature of each patient's progress. The influence of isokinetic testing on these structures will no doubt enhance our current state of knowledge about the effects of functional rehabilitation on low back dysfunction.

Force, Load and Lifting Considerations

As biomechanics has been defined to entail all forces acting on or within the body, the expression of muscular force, load application and the mechanics of lifting can be addressed from a perspective of both physiology and physics. There are definite responses to the production of muscular force, or exercise, that are dependent on its intensity, duration, frequency and the physiological status of the individual.^{7a} With the application of load, muscles distribute forces that affect the bony lever system, which either move or statically acts upon a resistance. Established models of neural control and motor learning have been challenged by investigators based on recent mechanical descriptions of the nervous system output and how movement is affected. These new theories have clinical impact in relation to the mechanics of lifting. The following review of these concepts is designed to provide the clinician with a better understanding of the factors affecting his or her isokinetic testing results and how those results may pertain to functional tasks.

Expression of Muscular Force

Skeletal, cardiac and smooth muscles are chemomechanical transducers; that is, they convert chemical energy to mechanical and heat energy. The contractile characteristics of skeletal muscle are mediated by a number of factors. These include the bony lever system, motor unit recruitment pattern, muscle fiber type and the neural mechanisms of muscular control. Because the lever system for a given individual is relatively unchanging except during growth, it is the pliant factors that are of clinical importance when techniques are undertaken to influence the expression of muscular force.

The purpose of physical training is to stress the body systematically so that it improves its capacity to withstand physical stress. This training is beneficial only as long as the body is forced to adapt to the imposed demands. If the stress is not sufficient to overload the body, then no adaptation occurs. If a stress cannot be tolerated, then injury or over-training results.

Muscles are strengthened by increasing their size and by enhancing the recruitment and firing rates of their motor units. Generally, as an individual matures past the age of increases in strength come about mainly by neural adaptation, whereas younger individuals rely more on increases in muscle size. The maximal tension and speed of contraction of a given muscle or

muscle group will also vary depending on the recruitment pattern expressed by the individual. Muscular recruitment depends on pyramidal tract activity mediated by the inhibitory influences of Golgi tendon organs and other reflex mechanisms. Such examples highlight the point that muscular performance does not depend completely on the strength of the muscle.

Factors that determine the rate and type of strength gains resulting from training include overload, specificity, and reversibility. Overload involves a progressive and gradual application of additional stress to the system in which improvement is desired. The principle of overload is exemplified by work on the synthesis of protein in muscle by Goldberg*. His procedures demonstrated that the rate of protein synthesis in a muscle is correlated with the rate of entry of amino acids into the cells. Goldberg also showed that amino acid transport into muscle is influenced directly by the intensity and duration of muscle tension. Therefore, maximal intensity, long duration muscular contraction is one of the primary stimuli to muscle growth. Proper rest periods between exercises and training sessions, and progression of overload are other critical factors in achieving maximal strength gains.

The effects of overload are specific to the type of stress applied and to the particular system of the body that is exercised. Specificity must be incorporated into a conditioning program to assure functional strength or endurance gains. Depending on the requirements of the contraction, there is preferential recruitment of motor units within a muscle. Slow-twitch fibers are relatively fatigue resistant, but have a low tension capacity. Fast-twitch fibers have a high tension capacity, but fatigue rapidly. Therefore, the selection of muscle fiber depends directly on the intensity of the muscle contraction, not the speed. Low intensity, high repetition exercise will stress slow-twitch fibers, whereas high intensity, low repetition activity will cause hypertrophy of primarily the fast-twitch fibers. Maximal contractions require recruitment of both fiber types. It should also be noted that muscles can further be broken into two components; a.) contractile (i.e., actin-myosin crossbridges) and b.) non-contractile (i.e., connective tissue, tendon, sarcolemma, muscle sheath etc.). During a concentric contraction tension is generated by the coupling of the actin-myosin crossbridges, while tension produced during an eccentric contraction is generally related to the passive resistance of the non-contractile components of the muscle. Rehabilitative exercise can thus be geared toward specific adaptation, taking into account the patient's functional requirements, such as heavy, moderate, or light lifting.

Just as muscles adapt to overload by increasing their function, their disuse leads to decreasing strength and muscle mass. This principle of reversibility also underscores the selection of specific muscle fibers. In general, joint immobilization results in a faster rate of atrophy for slow-twitch muscle fibers. Jowitt* also found a predominant atrophy of slow-twitch fibers in the multifidus muscle in patients with derangements of the lumbar spine. In addition, immobilization affects muscle length, with sarcomeres added if the limb is immobilized in a lengthened position and lost if it is fixed in a shortened state. Biomechanical changes as a result of immobilization can also inhibit muscular performance. These include decreased glycogen, adenosine triphosphate (ATP), creatine phosphate (CP), and creatine. High-intensity isotonic

exercise and slow-speed isokinetic loading are associated with increases in muscle glycogen, CP, ATP, adenosine diphosphate (ADP), creatine, phosphorylase, phosphofructokinase (PFK) and Krebs cycle enzyme activity.

The physiologic strength capacity of human muscle is far beyond the demands of most activities, with neurologic reflex mechanisms and psychological factors restricting the amount of force that is expressed. The maximal tension a muscle is capable of producing is directly related to its thickness, or cross-sectional area. The tension developed by human skeletal muscle has been estimated to be 1 to 2 kg/cm. According to calculations by Farfan* the erector spinae are capable of producing approximately 275 to 295 kg (600 to 650 lbs) of force at 100% capacity. The gluteals can generate about 1000 to 1135 kg (2200 to 2500 lbs) of force and hamstrings 680 to 775 kg (1500 to 1700 lbs) of force. Most muscular function occurs at about 35% of capacity, with a maximal dead lift by a trained weight lifter still only approaching 67% of capacity.

Many other factors influence the biomechanics of muscular force production, with the aforementioned principles representing only a few. Once an external load or ballistic force is applied to the body, the muscular, neurologic and bony lever systems work together to ensure efficient distribution. Distribution of loads can therefore be thought of as both neurologic and mechanical processes.

Distribution of Loads

As external forces are absorbed by the internal structures of the spine, the forces generated must be distributed so that no one structure is over-stressed. Load distribution is determined by the skeletal, cartilagenous and ligamentous structures in conjunction with the dynamic action of the musculature. Because the first three structures are primarily static components, the contractile characteristics of the muscles provide the only means of dynamically influencing the nature of the force distribution. Sequencing of muscle firing is directly controlled by the central nervous system; therefore, examination of the motor patterns involved provides a basis for the understanding of load distribution.

According to Gracovetsky, Farfan and Lamy,* the feeling of being comfortable with a particular sequence of motion is a result of a complex decision making process undertaken by the nervous system. This process therefore controls the firing sequence of an individual's muscles. The firing sequence itself must then be broken down into an assemblage of coordinated decisions that are ultimately judged and interpreted by the brain as being "comfortable." The term "comfortable" may be interpreted as essentially an absence of pain, since pain would presumably result when the tissues were over-stressed. Therefore, if the subject has the choice of executing a task in such a way that the stress experienced in any part of the body is either high or low, the low stress action would most likely be selected.

This concept, also known as the theory of optimal control, leads to the notion that the muscle strategy which results in minimal stress at the intervertebral joints is the optimal one. While this theory remains open to debate, it provides a basis for studying the biomechanical effects of

lifting and other stressful actions on the spine. Morris* has calculated that a 170 lb man lifting a 200 lb weight may develop a 2071 lb reaction at the lumbosacral disc. Since this reaction is greater than the crush strength of the vertebral body, other mechanisms in addition to the disc and vertebral body must lend support. The disc, two facet articulations, and the interspinous and supraspinous ligaments contribute almost the entire resistive capacity of the joint itself. An additional mechanism for reducing the stress level at the intervertebral joint is intraabdominal pressure, which can be increased by a Valsalva maneuver. Calculations based on this concept suggest that intraabdominal pressure may reduce forces at the lumbosacral joint by 5 to 10%. Forces may be reduced by 10 to 20% by the thoracolumbar fascia and the curved shapes of the facet joints and facet joint capsules may also serve to diminish the compressive load on the disc. Although the musculature of the hips and legs may also be instrumental in decreasing some of these forces, their exact contribution remains unclear.

The TEF Modular Component was designed to allow these force reducing components to work most efficiently. Safety and functional motion are ensured by maintenance of the orientation of the spinal curves, secure stabilization and the combined hip/spine action. Allowing the subject to execute the motion naturally, with minimal intervention from the clinician, will theoretically promote optimal patterns of motor development within each individual.

Due to the fact that the first-time patient may exhibit excessive tension in response to the unfamiliarity of the testing environment, specific suggestions, such as reminding the subject to breathe appropriately, may be warranted.

Conclusion

The complexity of trunk motion necessitates consideration of movement over multiple joints as well as the functional applications of multiplanar movement. The trunk serves as an important stabilizing component to both the upper and lower extremities, involving an intricate network of neuromuscular impulses, muscular contractions and physiologic responses. The clinician must consider the spectrum of biomechanics and the needs of individual patients in developing comprehensive testing and rehabilitation programs with the CSMI TEF Modular Component and CSMI NORM Extremity Testing and Rehabilitation systems.

* Refer to the CSMI publication "Bibliography of Isokinetic Research, Clinical Study and Observation" for complete bibliographic references.

TRUNK: FLEXION/EXTENSION

Parts Needed

- TEF Modular Component

Reclining Chair Preparation

- Monorail Scale: Move and secure chair at End of monorail.
- Chair Rotation Scale: Rotate chair out of way.

Dynamometer Preparation

- Dyna Rotation Scale: Rotate dyna to face docking side of CSMI NORM System.
- Dyna Height Scale: Raise dyna so that the dyna input arm is higher than the TEF Modular Component's dynamometer docking adapter.
- Dyna Tilt Scale: 0°
- Flip both ROM Stops back, out of the way and rotate the long end of the dyna input arm to the 12 o'clock position.

Before using this pattern for the first time with the selected patient:

1. Dock the TEF Modular Component to the NORM System.
2. Access the NORM software's Pattern Selection Window.
3. Choose the Set AZ and Set ROM buttons in turn to establish a universal anatomical zero and range BEFORE placing the "first time" patient on the TEF Modular Component.

TEF Modular Component Docking

The TEF Modular Component should be securely docked to the CSMI Testing and Rehabilitation System **BEFORE** placing a patient on the unit.

- To **Hitch** the base of the TEF Modular Component to the NORM unit docking post.
 1. Move the TEF Modular Component to the NORM unit until the docking clamp on its docking hitch just touches the NORM unit docking post.
 2. Place a foot on the TEF Modular Component's rear base extension near the docking hitch end. Use that foot to push the TEF Modular Component toward the docking post engaging the clamp around the post. The teeth on the clamp should firmly grip the docking post.

For ease in hitching the TEF Modular Component to the NORM System, make sure the back wheel on the TEF Modular Component is parallel to the monorail base before "push—kicking" the docking hitch onto the NORM docking post.

- To **Dock** the TEF Modular Component to dynamometer.
 1. Move the TEF Modular Component's Input Arm Assembly fully forward (full flexion).
 2. Roll the TEF Modular Component toward the NORM unit until the dynamometer docking adapter on the TEF Modular Component is directly underneath the raised dynamometer input tube.
 3. Lower the short end of the dynamometer's input tube onto the NORM System's dynamometer docking adapter. Give the dynamometer docking adapter's knob a few turns to "finger tighten" the connection.
 4. Lock the dynamometer pedestal clamp.
 5. Raise the TEF Modular Component's input arm assembly to its full upright position (full extension) and securely tighten the dynamometer docking adapter knob.
 6. Lock all three of the TEF Modular Component's wheels.
- To **Verify** docking:
 1. Grasp the input arm assembly and move it through the range of motion. Check all connections making sure they are secure and that the input arm assembly moves freely within the range of motion.
 2. If the input arm assembly does not move freely within the range of motion, check to make sure there are no obstructions in its path (i.e., check ROM stop positions). Redock the TEF Modular Component if necessary.

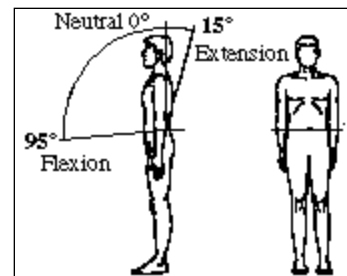

Figure 3-23 Trunk: Flexion/Extension

The axis of rotation is located at the L5/S1 level. Horizontal alignment is approximately 2 1/2" (3.5 cm) below top of iliac crest at L5/S1. Vertical alignment is the approximate intersection of the mid-axillary line and L5/S1.

The range of motion extends from 95° flexion to 15° extension from the neutral position.

Pattern Begins in Full Extension



Before Conducting the Session

1. Check that all clamps and knobs are secure
2. Check that the mechanical ROM stops are properly positioned according to the patient's range of motion, and that they are secure

Position Patient

- Make sure the TEF Modular Component's input arm assembly is at its fully extended position.
- Transfer patient to footplate.
 - Make certain that the patient places his/her heels flush against the footplate heel cups.
- Adjust the footplate height to align the patient's vertical anatomical axis with the machine axis.
 - Move the patient up or down, via the footplate switch, until the rubber alignment pointer is approximately 1½" (3.5 cm) below the top of the iliac crest. The pointer should be in direct line with the first segment below the iliac crest, (nominally L5/S1).
- Loosely fasten pelvic belt.
 - The pelvic belt should be loosely secured across the top of the anterior superior iliac spines.
- Adjust the popliteal pad height.
 - To raise or lower the popliteal pad, with one hand push and hold the popliteal pad locking lever toward the rear of the unit while adjusting the height of the pad to a position directly behind the patellae at the popliteal space.

- Insert the thigh pad.

Insert the thigh pad, locking lever pointing upward, into the thigh pad receiving tube.

- If the popliteal pad has been correctly aligned, the thigh pad will be positioned directly above the patellae with the receiving tube for the tibial pad below the patellae. The locking lever is pointing upward.
- Press the pad tightly against the thigh and secure by pushing forward on the locking lever. The thigh pad should be secure against the thigh but not so tight that it will impede blood flow or cause discomfort to the patient.

The THIGH PAD must always be installed BEFORE the Tibial Pad to ensure proper alignment.

- Insert the tibial pad.
 - Insert the tibial pad, locking lever downward, into the tibial pad receiving tube. Secure the pad just below the patellae as described as described for Thigh Pad.

Do not move the patient vertically once the thigh pad or tibial pad has been installed.

At this point, the patient's lower body is supported by the TEF Modular Component's stabilization system and he/she should feel comfortably stabilized.

- Adjust the fore/aft position.
 - Have the patient lean against the sacral/seat pad.

- Move the patient forward or back via the fore/aft alignment wheel, until the rubber alignment pointer is centered approximately at the intersection of the mid—axillary line and L5/S1.
- Check the security of the pelvic belt. Tighten it to a point such that it is very secure but not uncomfortable for the patient.
- Adjust the scapular pad height.
 - Release the pad by turning the scapular pad locking handle counterclockwise. Position the pad across the center of the scapulae inferior to the spine of the scapulae.
 - To lock the pad in place, turn the scapular pad locking handle clockwise.

Properly positioned and secured, the scapular pad and chest pad should be parallel.

- Secure the chest pad.
 - While the patient is holding the pad in position (hand grasp facing downward), buckle it and draw the belts tightly.
 - The pad should fit snugly against the patient's chest but still permit comfortable breathing.
- Perform several trial repetitions to check the patient's alignment.
 - Have the patient perform several trial repetitions, moving through the entire range of motion, and check alignment.
- If the patient is mis-aligned, his/her gluteals will ride up and down the sacral/ seat pad. If this occurs, first try making adjustments with the fore/aft alignment wheel. If that should fail, remove all stabilization and re-align the patient.
- If the chest pad rides up, remove it, lower the scapular pad and replace the chest pad. If this does not resolve the pad sliding, recheck the alignment.

Removing the patient from the TEF Modular Component

- Remove the chest pad and hang it on the chest storage bracket.
- Remove the thigh pad.
- Remove the tibial pad.

Have the patient support his/her own weight before removing the tibial or thigh pads.

- Unbuckle the pelvic belt.
- Lower the footplate via the footplate switch.
- Assist the patient off the footplate if necessary.

APPENDIX A. REPLACEMENT PARTS

This chapter describes the input adapters and accessories available with the NORM system. The input adapters are the various attachments used to exercise and test specific limbs and joints. Accessories include, for example, documentation and software delivered with the NORM system, consumable parts like printer ink cartridges, and other equipments like the cart used to store the input adapters.

The information supplied in this chapter is intended to supplement the adapter part description and part number information in Appendix D of the User's Guide manual. The information in this chapter provides a greater level of detail but does not obsolete the part descriptions in the User's Guide. Those descriptions can continue to be used when general information about the adapters is needed.

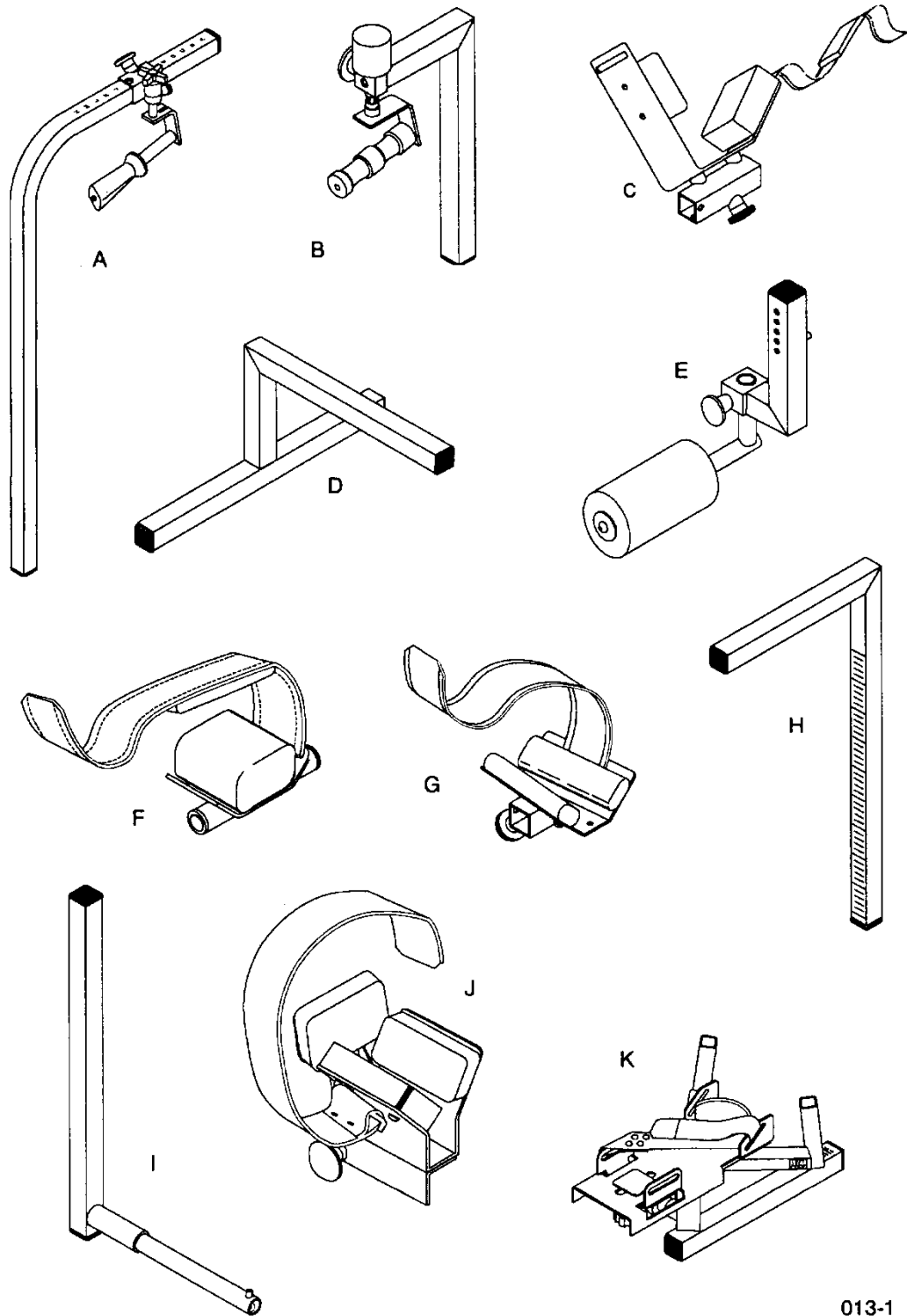

013-1

Figure 3-24 NORM System Adapters

NORM SYSTEM ADAPTERS

The figure on the facing page describes the input adapters packaged with the NORM system. Adapter accessories, such as the

Stabilization Utility Strap and the Coated Counter Weight, and other replaceable items, such as the lumbar and support cushions, are described later in this chapter. These items are also supplied with the NORM system.

ITEM	DESCRIPTION	PART NUMBER
A.	Elbow/Shoulder Adapter Assembly	7700S780
B.	Wrist/Shoulder Adapter Assembly	7700S960
C.	Thigh Stabilization Adapter Assembly	7700A870
D.	Foot Rest Assembly	7700S845
E.	Contralateral Limb Stabilizer	7700A240
F.	Shin Pad Adapter	7700A804
G.	Forearm Stabilization Adapter	7700A850
H.	Stabilizer Tube Assembly	7700S865
I.	Knee/Hip Adapter Assembly	7700A814
J.	Elbow Support Subassembly	7700S915
K.	Ankle Adapter Assembly	7700S886

NOTE: The Ankle Adapter Assembly includes the Ankle Arm Assembly. Previously, the Ankle Arm Assembly was supplied as a separate part with its own part number (770S885).

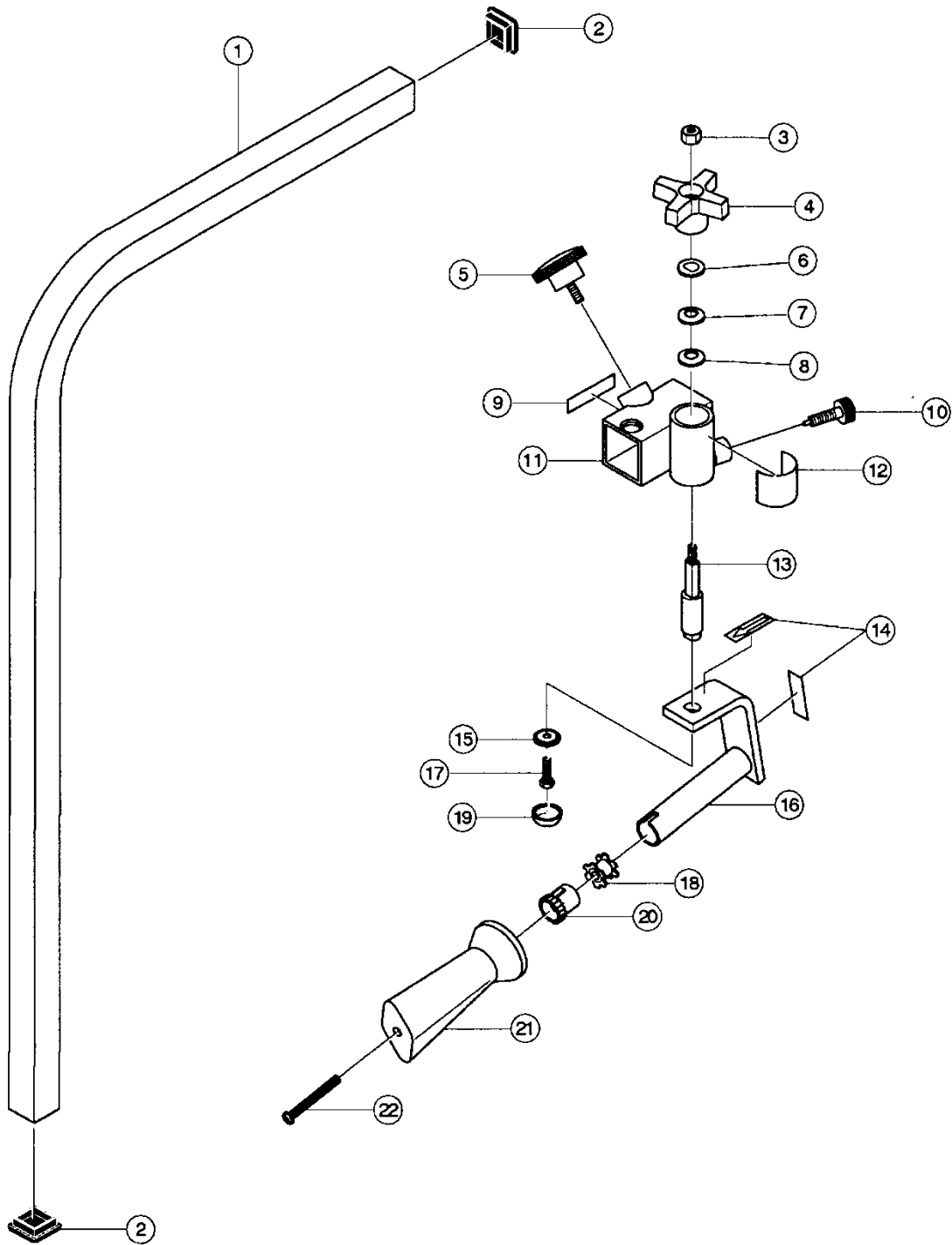

011-1E

Figure 3-25 Elbow and Shoulder Adapter (P/N7700S780)

REPLACEMENT PARTS

Replaceable Parts

REF. NO.	PART NO.	QTY	DESCRIPTION
1.	7700M977	1	Bent Tube, Elbow/Shoulder
2.	PP300013	2	Insert Guide, 1-1/4 Sq. x 16 GA.
3.	HN626300	1	Nut, Hex Nylox, 1/4-28 UNF-2B
4.	PP460771	1	Knob, with 3/8-24 Brass Insert
5.	PP460004	1	5/16-18 Black Knob Assembly
6.	HS390770	1	D-Washer, 3/8 ID x 3/4 OD x .09 Thick
7.	HS387705	7	Washer, Belleville, 1/2 x .035
8.	HS387604	1	Thrust Washer, .5 ID x .937 OD x .092 Thick
9.	730CM011	1	Label, "Right Ext/Flx"
10.	HF709420	1	Plunger, Hand Retractable, 3/8-16
11.	7700C975	1	Sliding Tube Weldment
12.	730CM024	1	Label, Shoulder Adapter
13.	7700C783	1	Handle Weldment
14.	730CM018	2	Label, Arrow Indicator (Dark Background)
15.	HS010003	1	Washer Screw Cap 1/4
16.	7700C783	1	Handle Weldment
17.	HC621212	1	Screw, Hex Head Cap, 1/4-20 UNC x 1/2
18.	HF449060	1	Insert, 7/8 x 1/4-20, Too Star
19.	PP080005	1	Screw Cap, Black
20.	P660003	1	Crutch Handle Plug
21.	PP410004	1	Orthoease Handgrip Gray Type B
22.	HM620228	1	Slotted Binding HD, 1/4-20 x 2-1/4

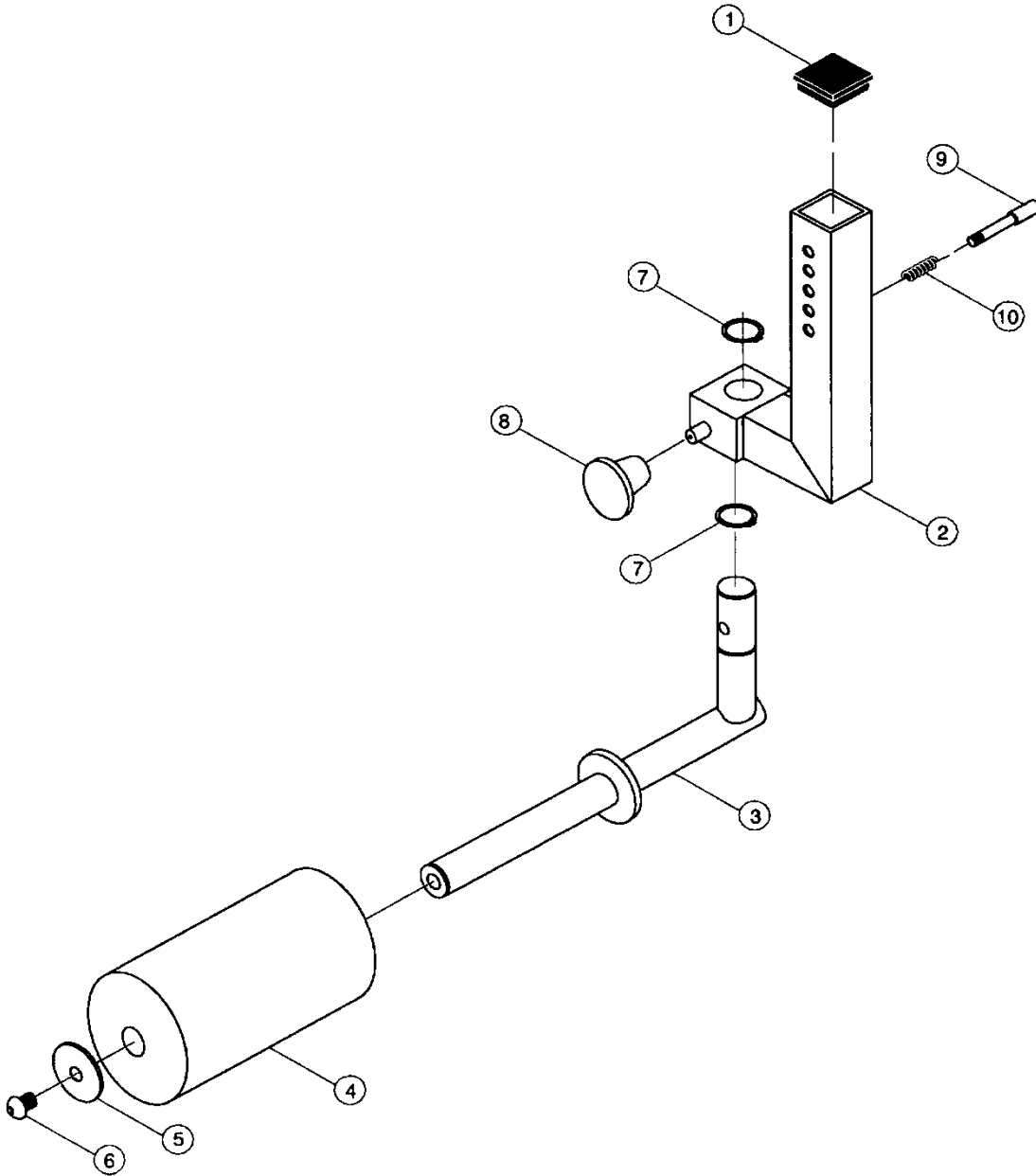

001-1E

Figure 3-26 Contralateral Limb Stabilizer (P/N 7700A240)

REPLACEMENT PARTS

Replaceable Parts

REF. NO.	PART NO.	QTY	DESCRIPTION
1.	PP300013	2	Insert Glide, 1-1/4"
2.	7700W459	1	Contralateral Stabilization Bar
3.	7700C455	1	Roller Bracket
4.	PP400013	1	Roller Pad, Self Filming, 3-1/4
5.	3400C468-1	1	Flat Washer, Black
6.	HC700412	1	Button HD Cap Screw, 3/8-16 x 1/2
7.	BR030042	2	Snap Ring, External, 7/8
8.	PP450201	1	Plastic Knob
9.	7700M463	1	Pull Pin
10.	BS071367	1	Spring, Compression

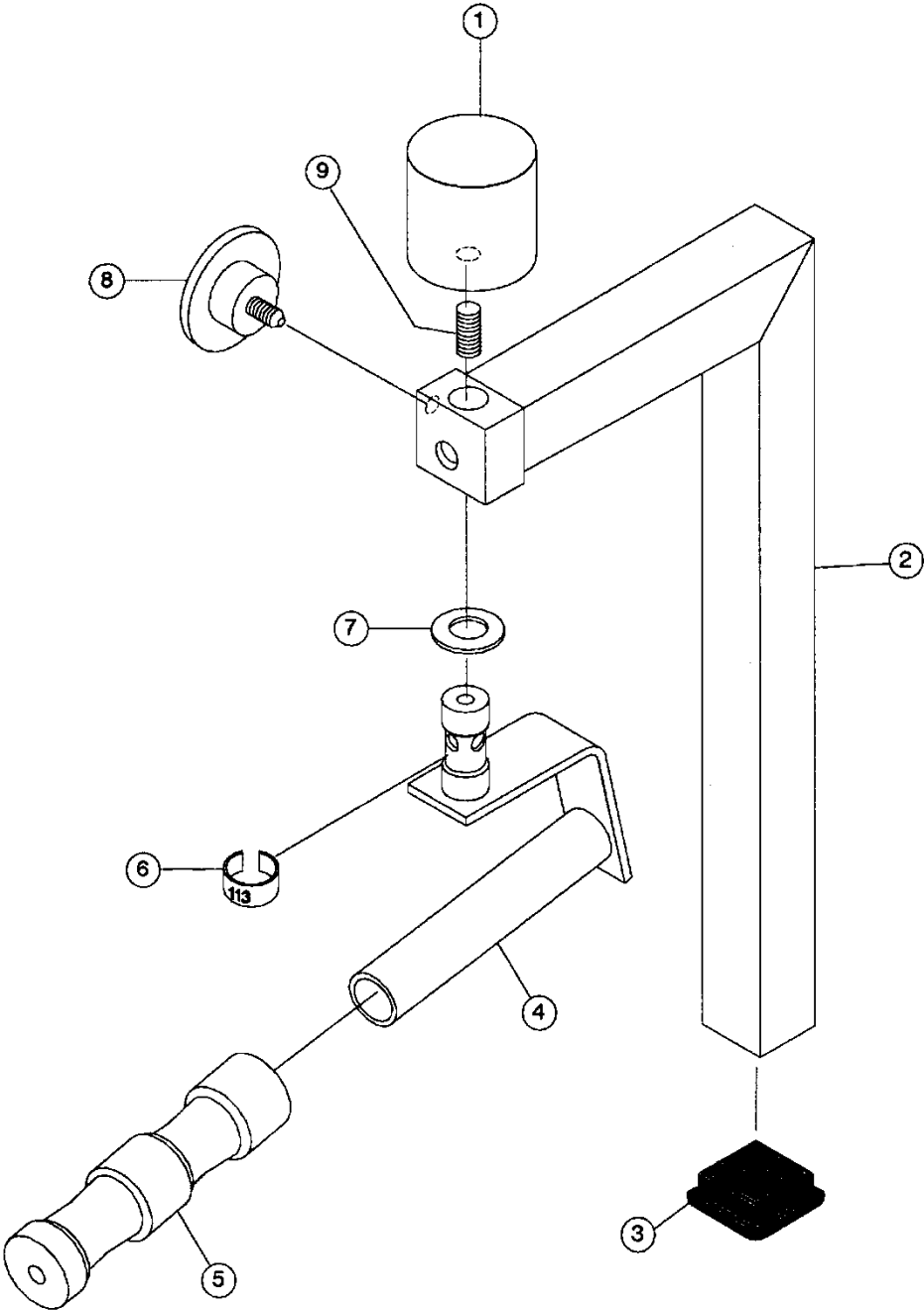

004-1E

Figure 3-27 Wrist and Shoulder Adapter Assembly (P/N 7700S960)

REPLACEMENT PARTS

Replaceable Parts

REF. NO.	PART NO.	QTY	DESCRIPTION
1.	7320C121-1	1	Counter Weight, Black
2.	7700W961	1	Wrist/Shoulder Adapter Weldment
3.	PP300013	1	Insert Glide 1-1/4 Sq. x 16GA.
4.	7700C965	1	Handle Weldment, Wrist/Shoulder
5.	PP400201	1	Hand Grip (Fly)
6.	770CM969	1	Label, Wrist/Shoulder Position
7.	FB030100	1	Thrust Washer, .750 ID x 1.25 OD x .06 Thick
8.	PP460774	1	Knob, with 5/16-18 x 3/4" Stud
9.	7320M122	1	Stud

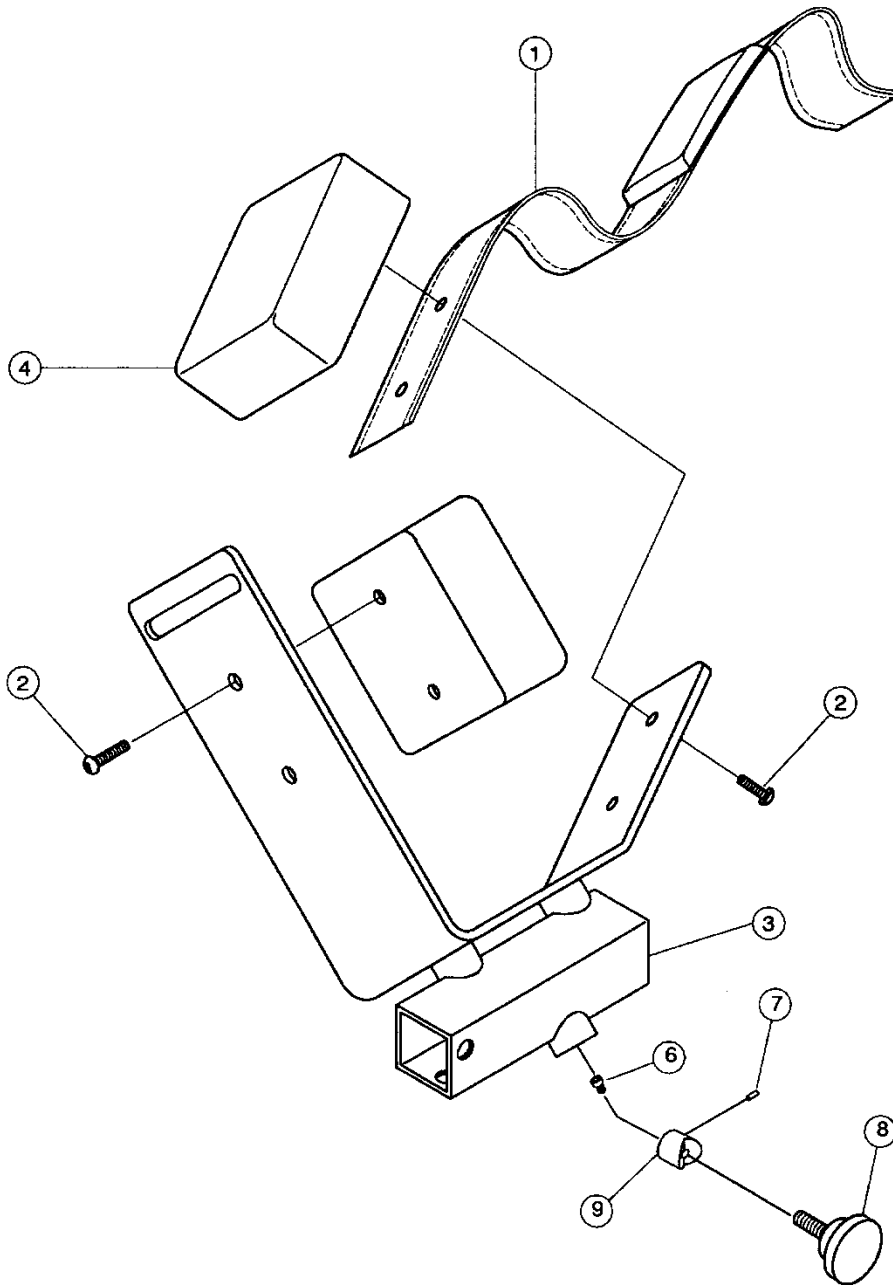

012-1E

Figure 3-28 Thigh Stabilization Adapter Assembly (P/N 7300S950)

Replaceable Parts

REF. NO.	PART NO.	QTY	DESCRIPTION
1.	7700U805	1	Shin Pad Belt
2.	HC620417	4	Screw, Socket Button Head, 1/4-20 x 1"
3.	7700C872	1	Thigh Plate/Side Weldment
4.	PP460004	1	Knob, 5/16-18, Black
5.	7700S802	2	Cushion
6.	HC532807	1	Screw, Socket Head Cap 6-31 x 1/4, Nylok
7.	HP246708	1	Roll Pin, 3/32 x 1/4
8.	PP460004	1	Knob, 5/16-18, Black
9.	AA033904	1	V-Pusher

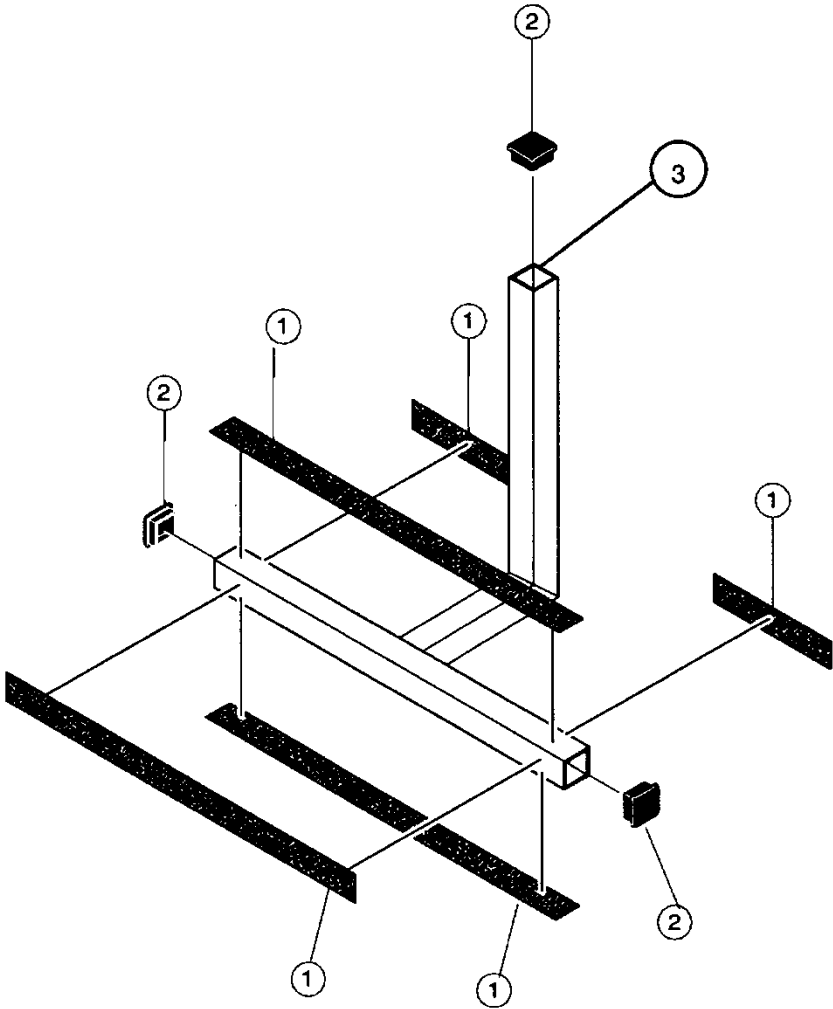
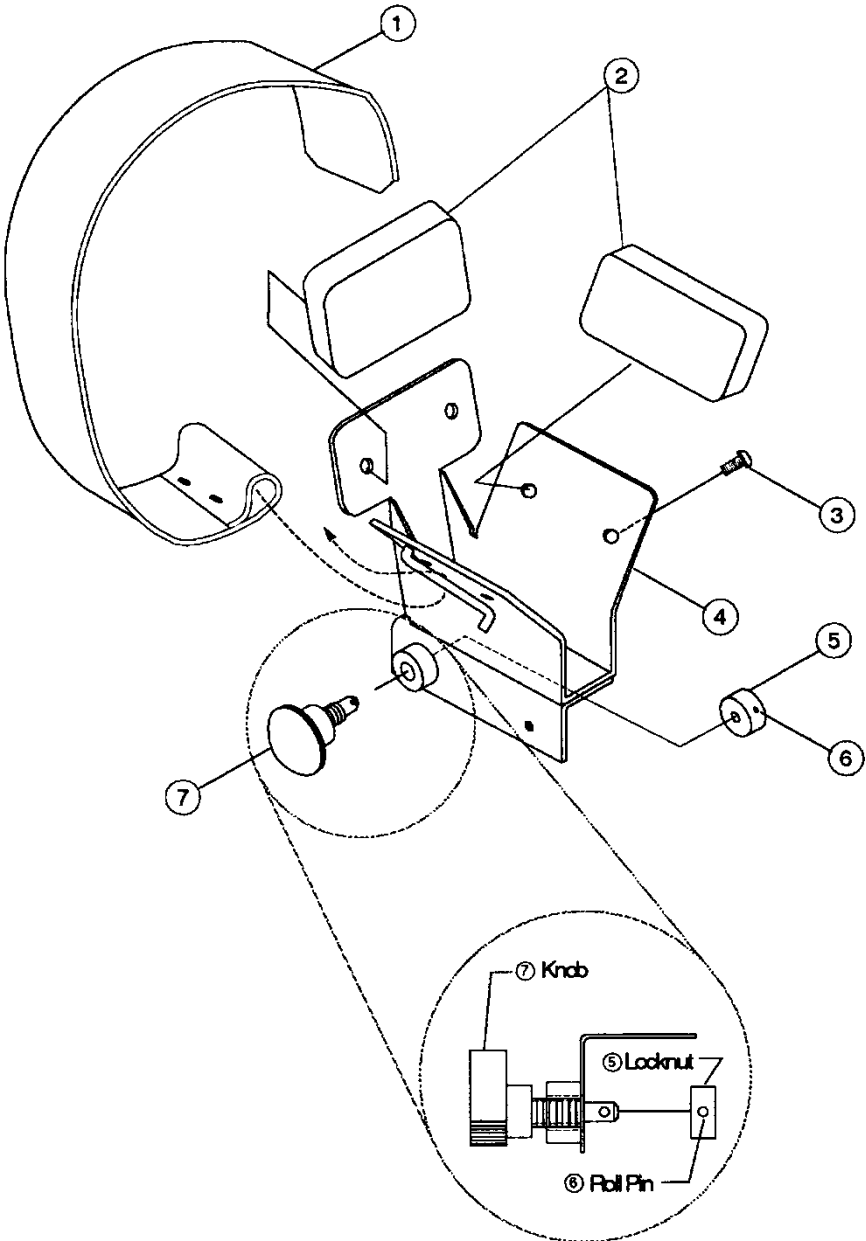

Figure 3-29 Foot Rest Assembly (P/N 7700S845)

REPLACEMENT PARTS

Replaceable Parts

REF. NO.	PART NO.	QTY	DESCRIPTION
1.		1	Non-Skid Foot Treads
2.	PP300013	3	Insert Glide, 1-1/4" Sq. x 16 GA.
3.	7700W840	1	Welded Foot Rest



002-1E

Figure 3-30 Elbow Support Subassembly (P/N 7700S915)

Replaceable Parts

REF. NO.	PART NO.	QTY	DESCRIPTION
1.	1810S189	1	Shoulder Rotation Belt Subassembly
2.	2500S001	3	Cushions
3.	HC620412	6	Screw, Hex Socket Button Head, 1/4-20 x 1/2
4.	7700C912	1	Elbow Stabilization Weldment
5.	7300P142	1	Locknut
6.	HP266723	1	Roll Pin, 1/8 Dia. x 5/8 Long
7.	PP460030	1	Knob, 3/8-16 Stud, L.H. Thread

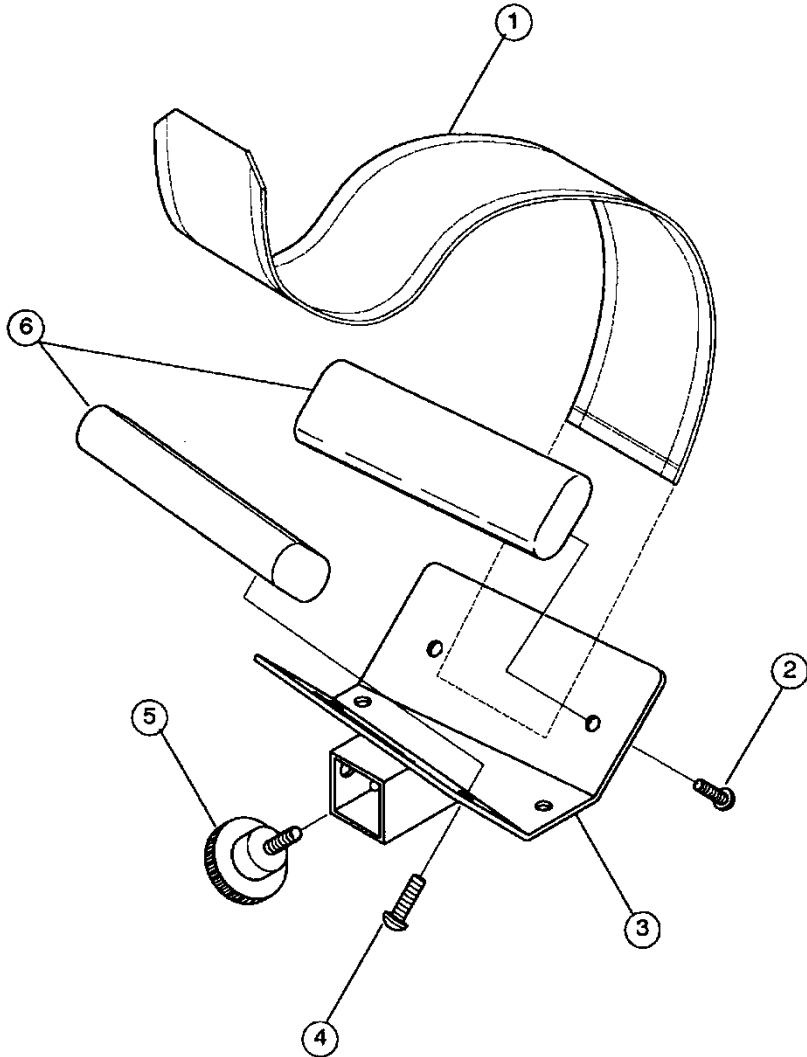

009-1E

Figure 3-31 Forearm Stabilization Adapter (P/N 7700A850)

Replaceable Parts

REF. NO.	PART NO.	QTY	DESCRIPTION
1.	UB410001	1	Forearm Stabilization Belt
2.	HC620417	4	Screw, Socket Button Head, 1/4-20 x 1
3.	7700C852	1	Forearm Slide Weldment
4.	HC620417	4	Screw, Socket Button Head, 1/4-20 x 1
5.	PP460004	1	Knob, 5/16-18, Black
6.	2500S001	2	Forearm Cushions

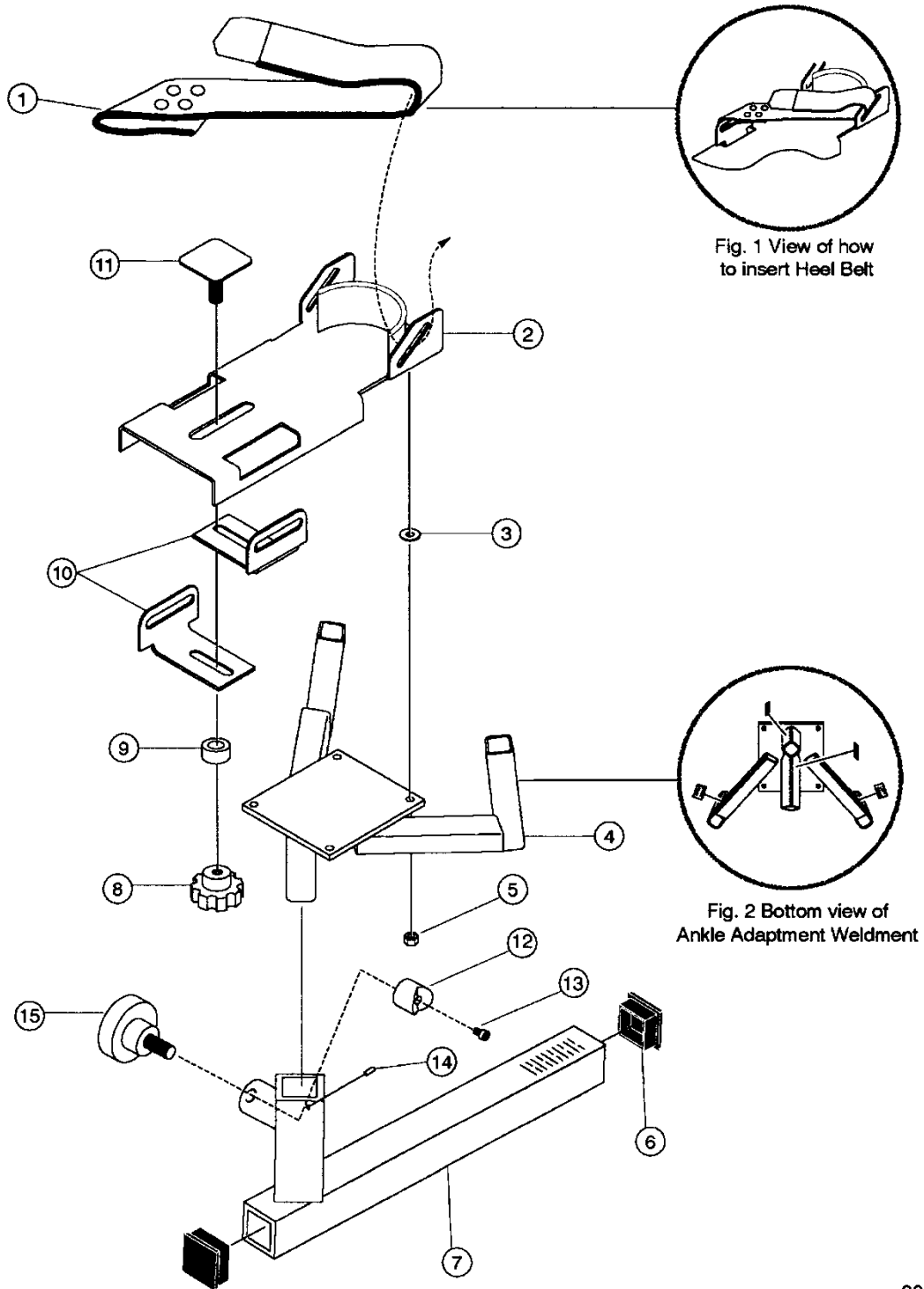
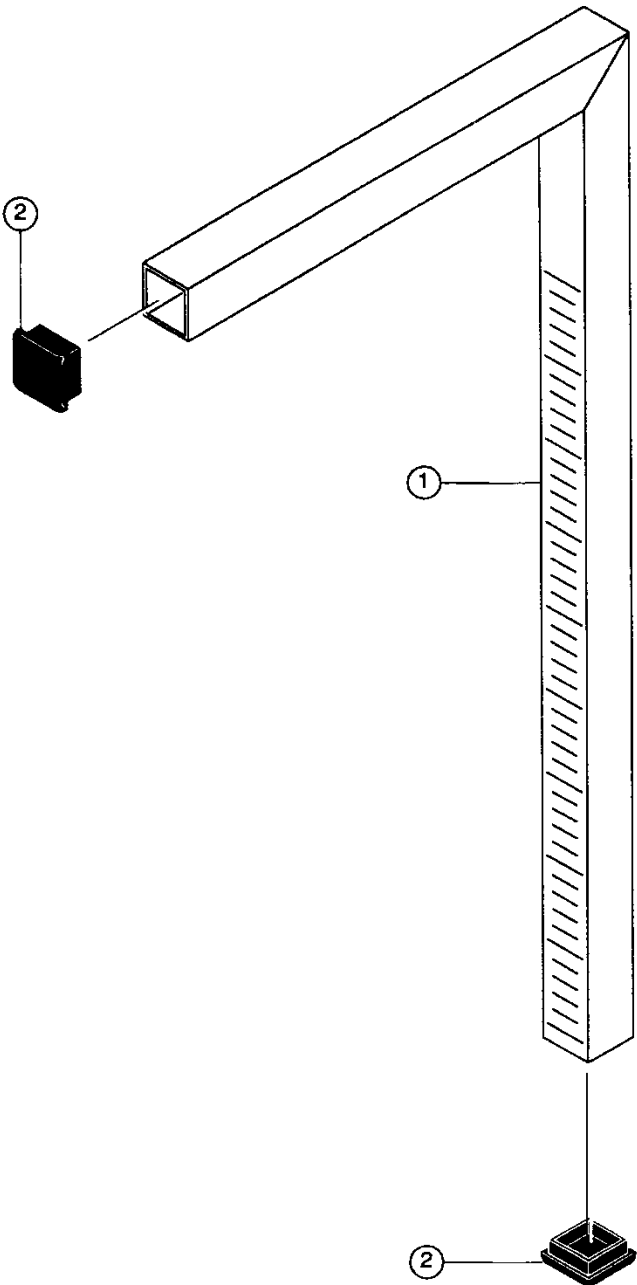

Figure 3-32 Ankle Adapter Assembly (P/N 7700S886)

005-1E

Replaceable Parts

REF. NO.	PART NO.	QTY	DESCRIPTION
1.	7300S978	2	Heel Belt Assembly
2.	7700C884	1	Ankle Plate Weldment
3.	HS307600	4	Flatwasher, 1/4 (5/8 OD x 9/32 ID x .062 Thick)
4.	7700W836	1	Ankle Adapter Weldment
5.	HN625200	4	Nut, .25–20 Ounce–3B Elastic Strip
6.	PP300013	2	Insert Glide, 1–1/4 Sq. x 16 Ga.
7.	7700W881	1	Ankle Arm Weldment
8.	PP460010	1	Locking Knob
9.	7300M035	1	Knob Spacer
10.	7700C831	2	Slide Support, Ankle Adapter
11.	7300C038–1	1	Threaded Stud Weldment, Black
12.	AA033904	1	V–Pusher
13.	HC532807	1	Screw, Socket Head 6–31 x 1/4, Nylok
14.	HP246708	1	Roll Pin, 3/32 x 1/4
15.	PP460008	1	Locking Knob



010-1E

Figure 3-33 Stabilizer Tube Adapter (P/N 7700S865)

REPLACEMENT PARTS

Replaceable Parts

REF. NO.	PART NO.	QTY	DESCRIPTION
1.	7700W860	1	Stabilizer Tube Weldment
2.	PP300013	2	Insert Glide, 1-1/4" Sq. x 16 Ga.

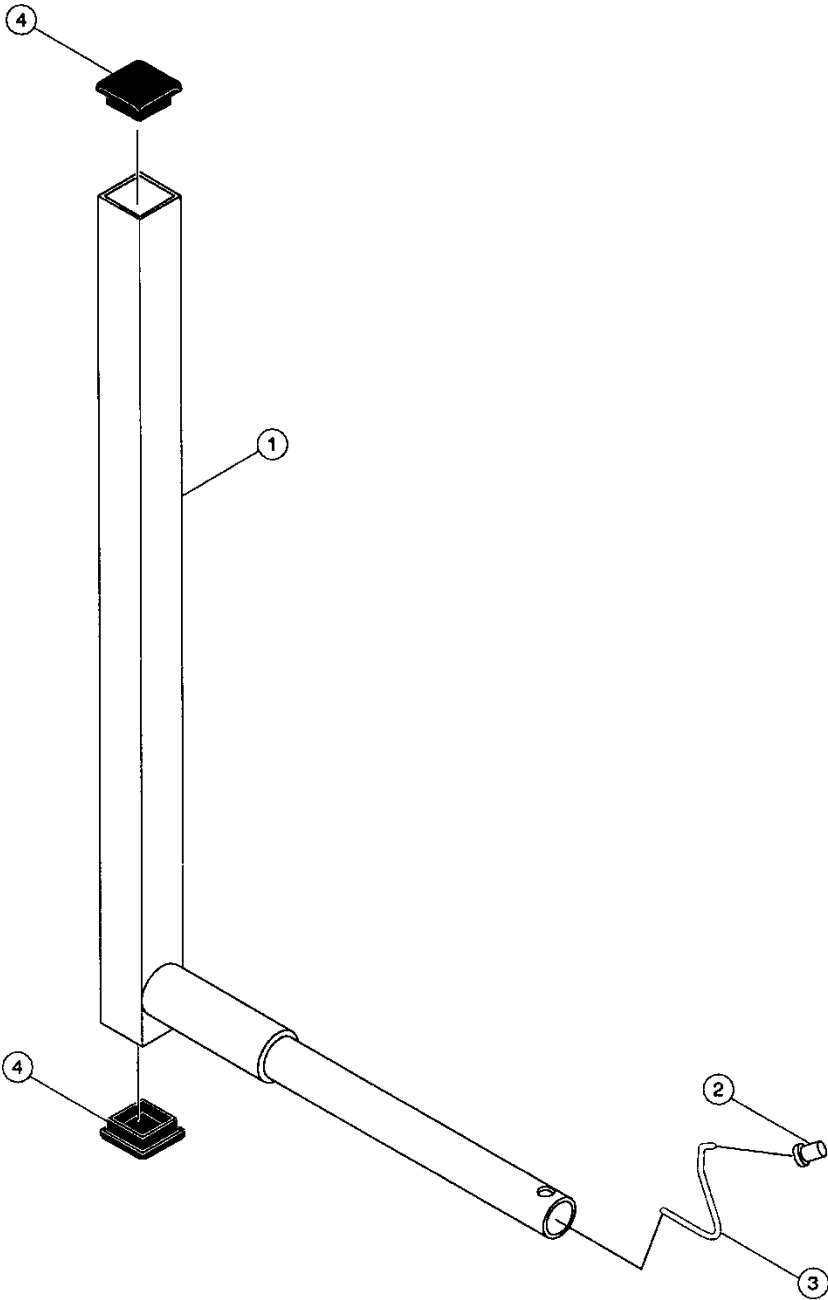

006-1E

Figure 3-34 Knee and Hip Adapter (P/N 7700A814)

Replaceable Parts

REF. NO.	PART NO.	QTY	DESCRIPTION
1.	7700W813	1	Knee/Hip Adapter Weldment
2.	AP030006	1	Push Button
3.	BS070017	1	Spring – Wire, .062 Dia
4.	PP300013	2	Insert Glide, 1–1/4 Sq. x 16 Ga.

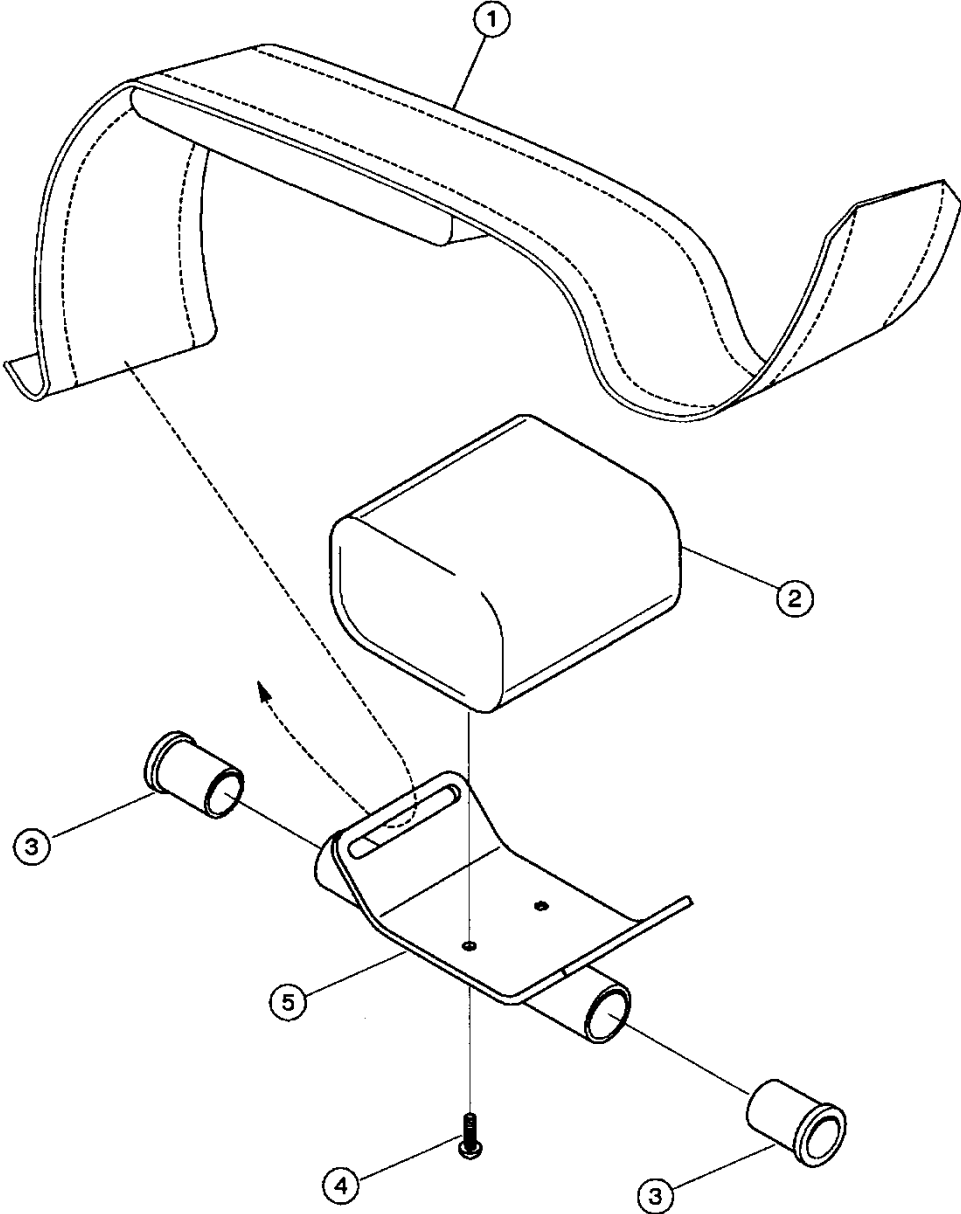

008-1E

Figure 3-35 Shin Pad Adapter (P/N 7700A804)

Replaceable Parts

REF. NO.	PART NO.	QTY	DESCRIPTION
1.	7300U805	1	Shin Pad Belt
2.	7700S802	1	Shin Pad
3.	AD120000	2	Pad Tube Cushion
4.	HC620417	2	Screw, Socket Button Head, 1/4-20 x 1"
5.	7700C801	1	Shin Pad Retainer Weldment

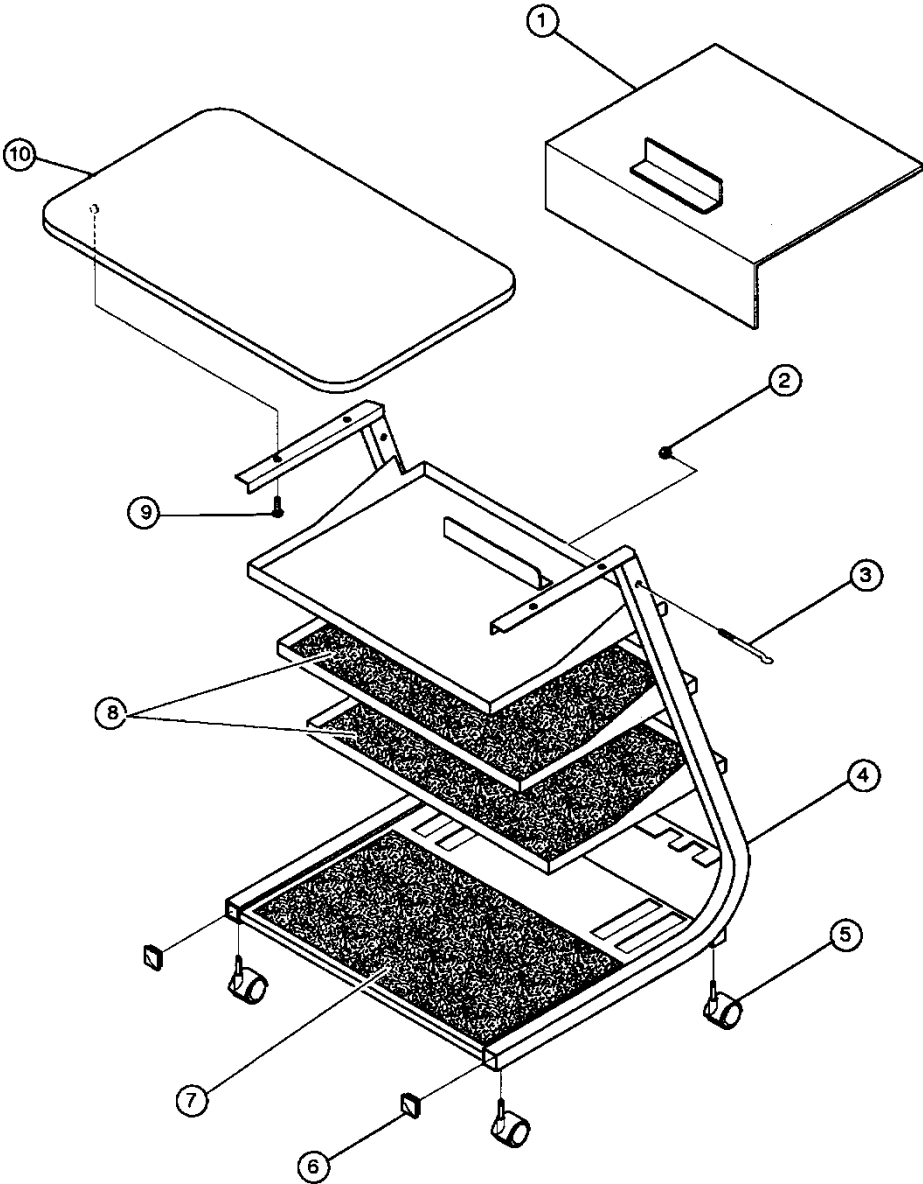

014-1E

Figure 3-36 Accessory Cart (P/N 770OF090)

REPLACEMENT PARTS

Replaceable Parts

REF. NO.	PART NO.	QTY	DESCRIPTION
1.	7300C078	1	Paper Basket
2.	HN5825200	2	Elastic Stop Nut #10
3.	7300P099	2	Hangar Bars
4.	7700F090	1	Cart
5.	WB04001	4	Caster w/Brakes, 5/16–18 Stem
6.	PP300003	2	End Cap, 1–1.4 Sq, 14Ga.
7.	7300M082	2	Weight Shelf Mat
8.	7300M081	1	Accessory Shelf Mat
9.	HM582214–2	4	Pan L Screw, 10/32 x 5/8 (Gray)
10.	730PE090	1	Table Top

NORM ACCESSORIES

7700U525	Stabilization Utility Strap
7320C121	Coated Counter Weight
7700S456	Support Cushion
7700S516	Lumbar Cushion

CONSUMMABLE PARTS

DB020502	Box of 10, 3 1/2" DS HD Diskettes
DC010009	Mini Data Cartridge Tape
DC030001	3 1/2" Drive Cleaning Kit
DR020009	HP Printer Cartridge, Color
DR020008	HP Printer Cartridge, Black

DOCUMENTATION

7700D4000	NORM Assembly and Installation
7700D0001	NORM Quick Start Manual
7700D0000	NORM User's Guide

SOFTWARE

770SW-DEU	Software Platform – German
770SW-DUT	Software Platform – Dutch
770SW-ENG	Software Platform – English
770SW-ENG/MET	Software Platform – English/Metric
770SW-ESP	Software Platform – Spanish
770SW-ESP/ENG	Software Platform – Spanish/English
770SW-FRE	Software Platform – French
770SW-ITA	Software Platform – Italian
770SW-JPN	Software Platform – Japanese
770SW-NOR	Software Platform – Norwegian
770SW-SWE	Software Platform – Swedish
770SW076	Software, DOS, 3-1/2" Media

770SW077 Software, Windows, 3-1/2" Media

HARDWARE

EN040030 Computer

EN380016 Monitor

EN770001 Light Pen

EK390010 Keyboard

EN490060 Printer

OPTIONS

EP500005 Uninterruptible Power Supply

7700S758 High Torque Servo Amp DM-75

7700S755 KINESTIM Auxiliary Interface

2600F770 Johnson Anti-Shear Accessory

7310A001 TEF Modular Component (TMC)

THE JOHNSON ANTI-SHEAR ACCESSORY

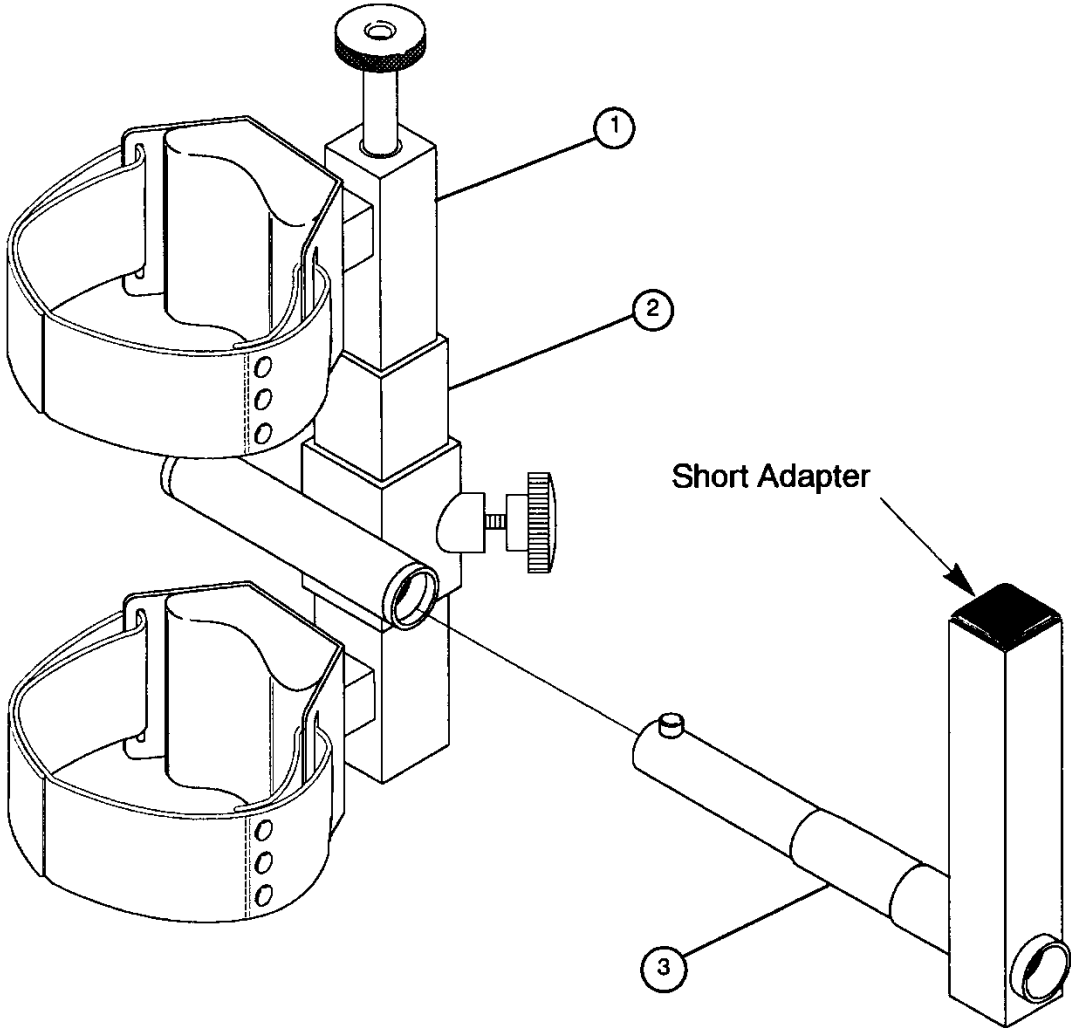

022-1

Figure 3-37 The Johnson Anti-Shear Accessory

Replaceable Parts

ITEM	DESCRIPTION	PART NUMBER
1.	Accessory	2600F770
2.	Pivot Arm	2600C004
3.	Sleeve	7700M890

WORKSIM ADAPTERS AND ACCESSORIES

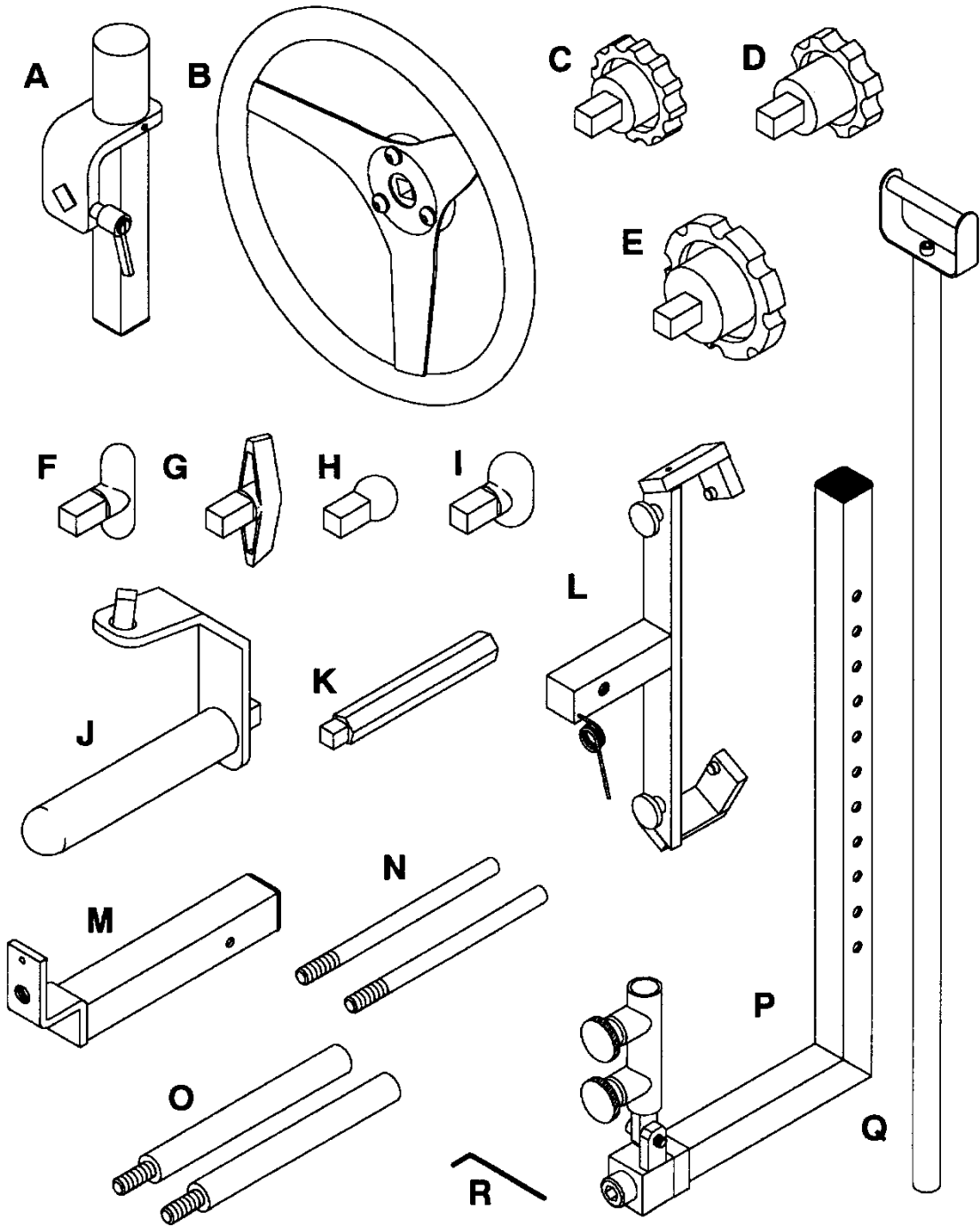

015-1

Figure 3-38 Work Simulation Adapters and Accessories

ADAPTER AND ACCESSORY LISTING

ADAPTER	DESCRIPTION	PART NUMBER
A	Universal WorkSim Adapter	7720A100
B	Steering Wheel/Valve Adapter	7720A400
C	Small Fluted Knob Adapter	7320A600
D	Small Fluted Knob w/Large Offset	7320A610
E	Large Fluted Knob	7320A640
F	Small T-Handle	7320A660
G	Large T-Handle	7320A670
H	Spherical Knob	7320A620
I	Oval Knob	7320S650
J	Multi-Grip / Screwdriver Adapter	7720A630
K	Universal Tool Adapter	7320P201
L	Stationary Gripper Arm	7720A300
M	Gripping Device	7720A300
N	1/2" Diameter Handle (2 pieces)	7720C302
O	3/4" Diameter Handle (2 pieces)	7720C301
P	Push / Pull Input Arm	7720A500
Q	Simulation Handle	7720A500
R	1/8" Wrench	BK030125

UNIVERSAL WORKSIM ARM

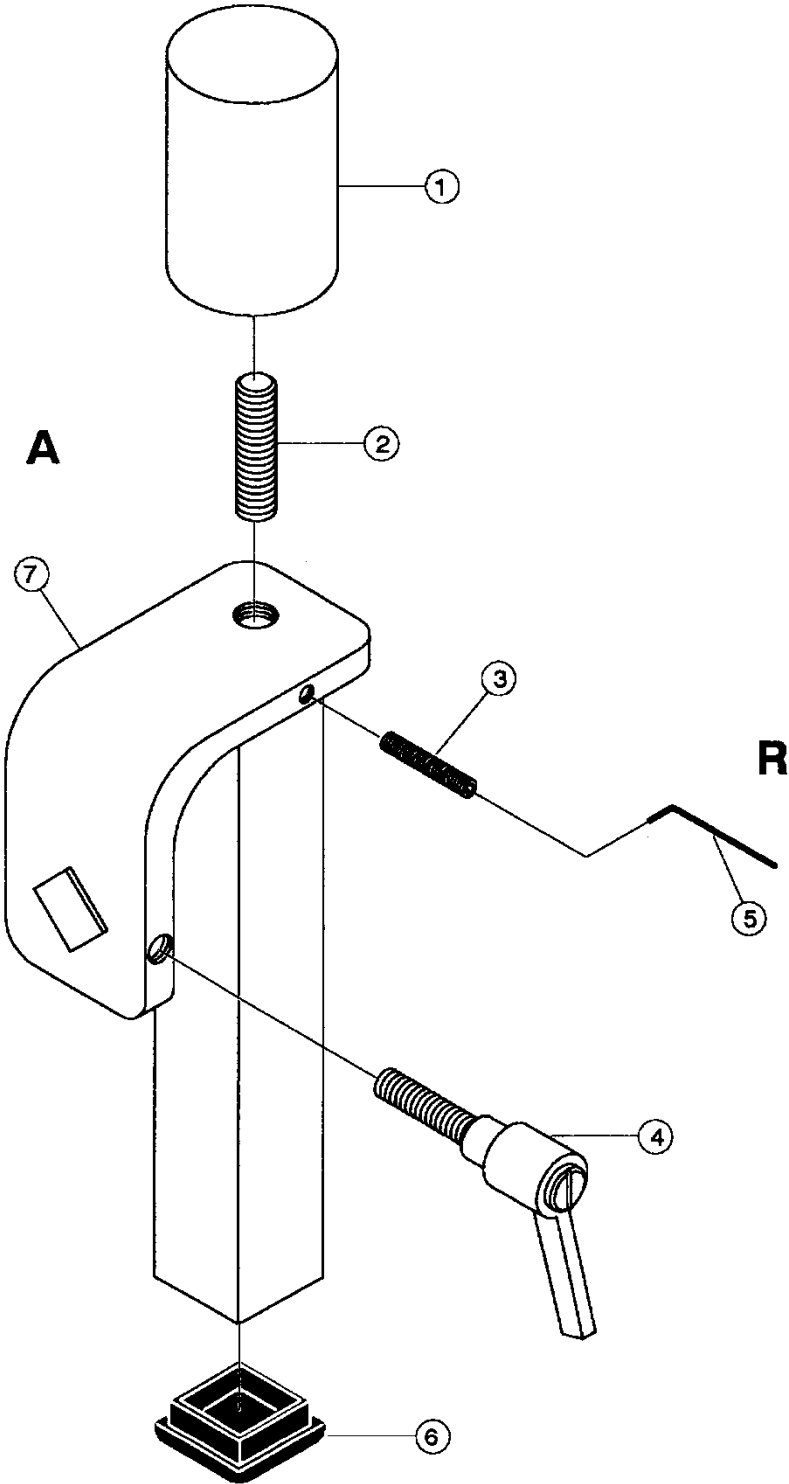

020-5A

Figure 3-39 Universal WorkSim Arm

REPLACEMENT PARTS

REPLACEABLE PARTS

REF. NO.	PART NO.	QTY	DESCRIPTION
A	7720C110		Universal WorkSim Arm Assembly
1.	7720C121-1	1	Counter Weight
2.	7720M122	1	Stud, 3/8 – 16 x 1-1/2
3.	HY622917	1	Socket Head Screw, 1/4–20x1
4.	BH030019	1	Adjustable Handle
5.	BK030125	1	Allen Wrench, 1/8
6.	PP300013	1	Insert Glide, 1-1/4" sq. x 16 ga.
7.	7720C110	1	Universal WorkSim Weldment

ADAPTER USAGE

The Universal WorkSim Arm is used in DAP 201 through DAP 211 Pattern Set-ups.

STEERING WHEEL / VALVE ADAPTER

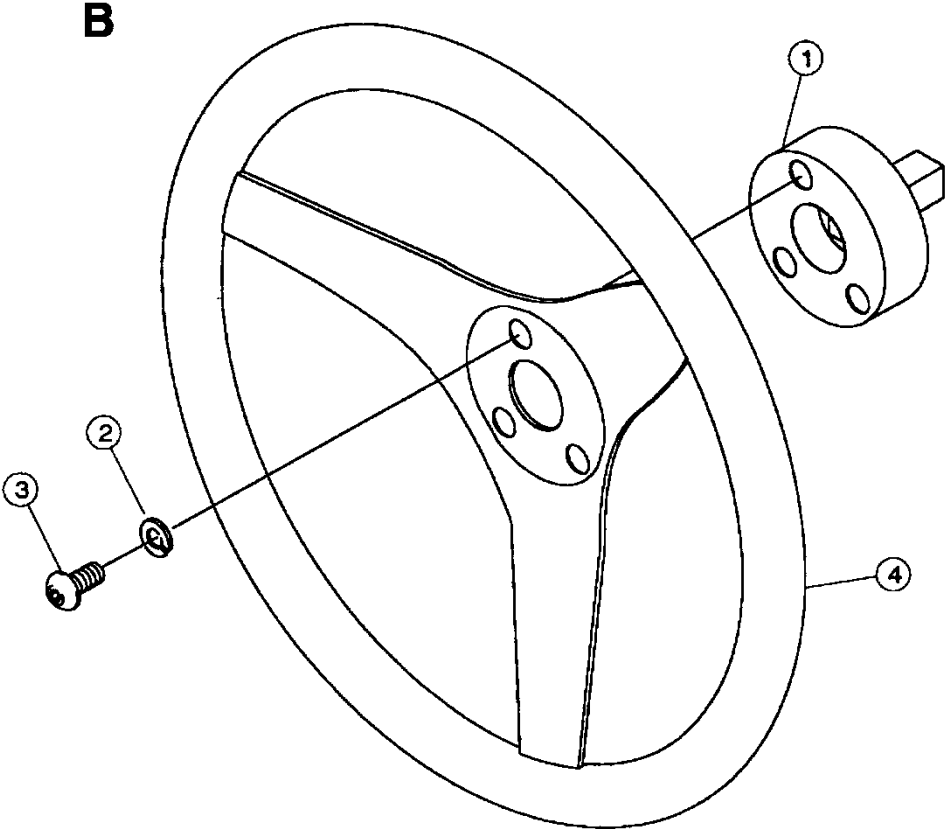

025-1A

Figure 3-40 Steering Wheel / Valve Adapter

REPLACEABLE PARTS

REF. NO.	PART NO.	QTY	DESCRIPTION
B	7720A400		Steering Wheel / Valve Assembly
1.	7720P408	1	Steering Wheel / Valve Weldment
2.	HS308300	3	Lockwasher, 1/4
3.	HC620412	3	Butt. Hd. Cap Screw, 1/4x-20x1/2
4.	732WW412	1	Steering Wheel / Valve Adapter

ADAPTER USAGE

The Steering Wheel / Valve adapter is used in DAP 201 Pattern Set-Up with the Universal WorkSim Arm.

HANDLES AND KNOBS

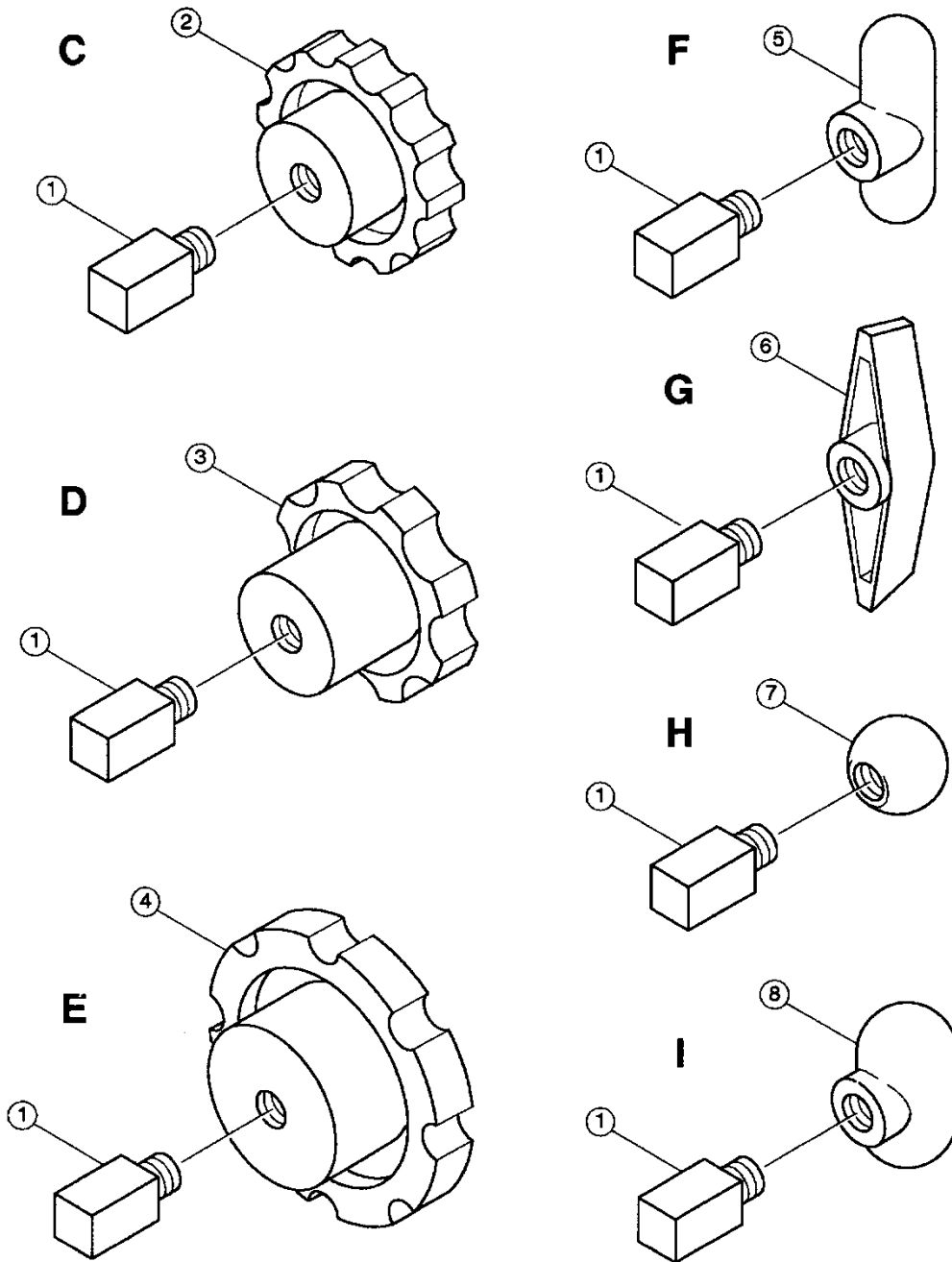

016-1E

Figure 3-41 Handles and Knobs

REPLACEABLE PARTS

REF. NO.	PART NO.	QTY	DESCRIPTION
C	7320A600		Small Fluted Knob Assembly
1.	7320P601	1	Threaded Knob Adapter, 3/8–16
2.	732PP602	1	Small Fluted Knob
D	7320A610		Small Fluted Knob with Offset
1.	7320P601	1	Threaded Knob Adapter, 3/8–16
3.	PP450005	1	Small Fluted Knob with Offset
E	7320A640		Large Fluted Knob assembly
1.	7320P601	1	Threaded Knob Adapter, 3/8–16
4.	732PP641	1	Large Fluted Knob
F	7320A660		Small "T" Handle assembly
1.	7320P601	1	Threaded Knob Adapter, 3/8–16
5.	732PP661	1	Small "T"–Handle
G	7320A670		Large "T" Handle assembly
1.	7320P601	1	Threaded Knob Adapter, 3/8–16
6.	732P671	1	Large "T"–Handle
H	7320A620		Spherical Knob assembly
1.	7320P601	1	Threaded Knob Adapter, 3/8–16
7.	732PP621	1	Spherical Knob
I	7320A650		Oval Knob assembly
1.	7320P601	1	Threaded Knob Adapter, 3/8–16
8.	732PP651	1	Oval Knob

ADAPTER USAGE

Handles and Knobs are used in DAP 202 through 208 Pattern Set–Ups with the Universal WorkSim Arm.

MULTI-GRIP / SCREWDRIVER ADAPTER MULTI-GRIP / SCREWDRIVER AND UNIVERSAL TOOL ADAPTERS

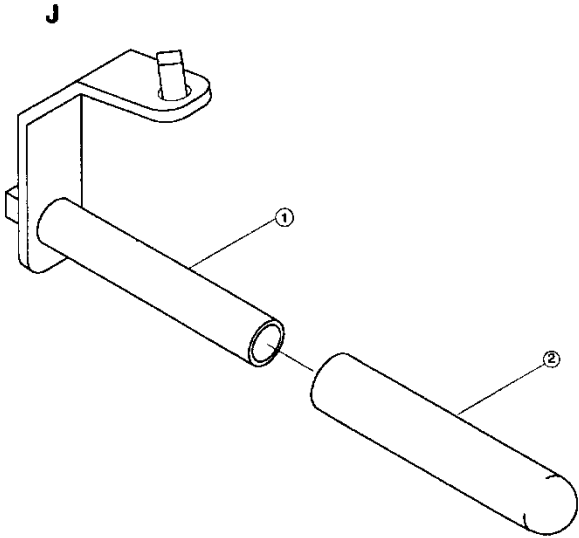

017-1E

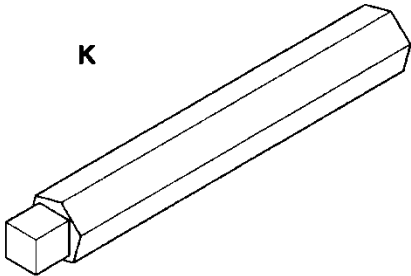

021-1A

Figure 3-42 Multi-Grip / Screwdriver and Universal Tool Adapters

REPLACEABLE PARTS

REF. NO.	PART NO.	QTY	DESCRIPTION
J	7720A630		Multi-Grip / Screwdriver assembly
1.	7720631	1	Multi-Grip Screwdriver Weldment
2.	732PP634	1	Rubber Hand Grip

ADAPTER USAGE

The Multi-Grip / Screwdriver adapter is used in DAP 209 and DAP 210 Pattern Set-Ups with the Universal WorkSim Arm.

REPLACEABLE PARTS

REF. NO.	PART NO.	QTY	DESCRIPTION
K	7320P201	1	Universal Tool Adapter

STATIONARY GRIPPER ARM

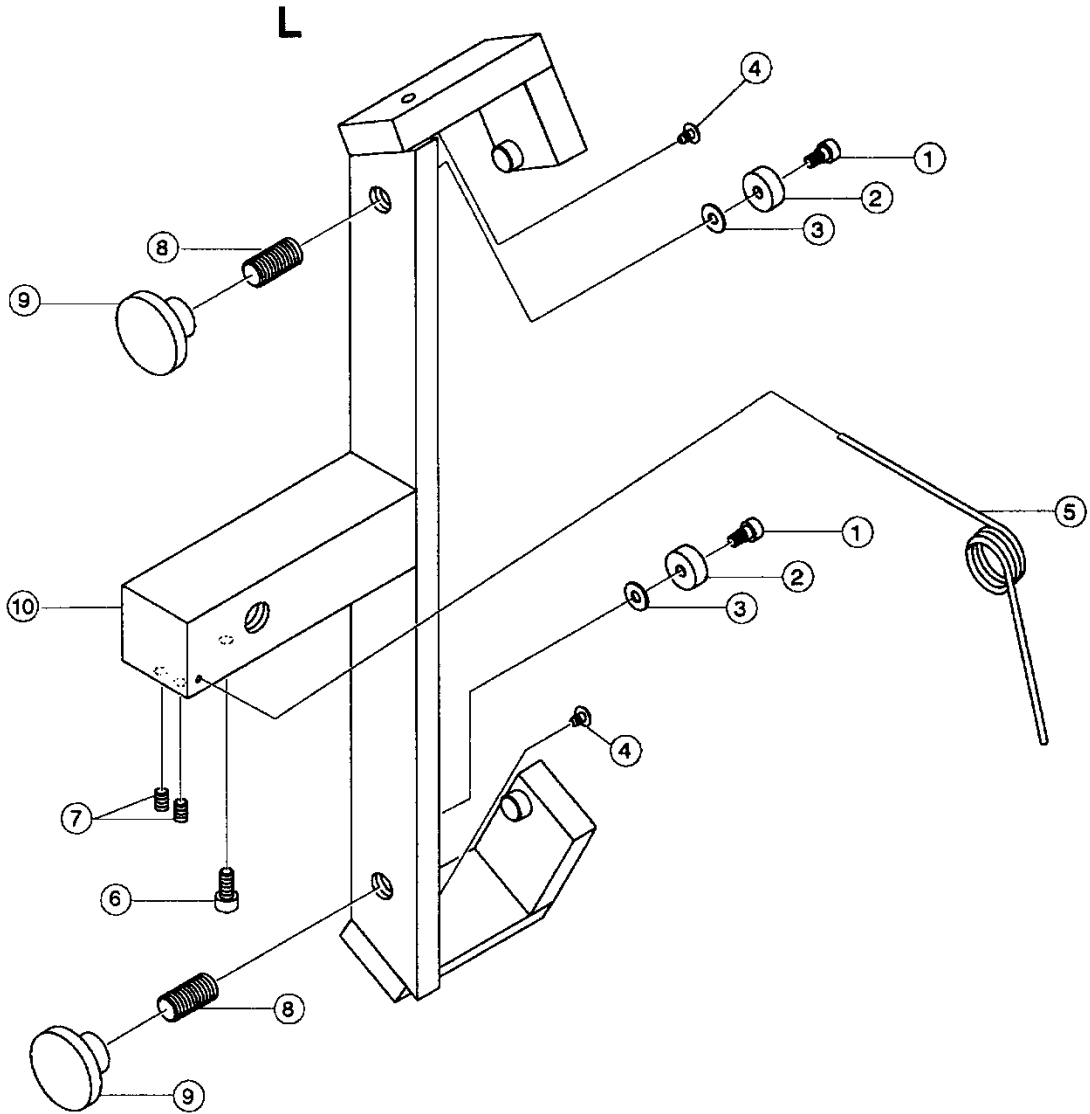

020-1E

Figure 3-43 Stationary Gripper Arm

REPLACEABLE PARTS

REF. NO.	PART NO.	QTY	DESCRIPTION
L	7720A300		Stationary Gripper Arm assembly
1.	HD583307	2	Slotted Shoulder Screw #10-32x14
2.	7320M305	2	R.O.M. Face Clamp
3.	HS107702	2	Flat Washer, 1/4"
4.	PP060010	2	Stem Bumper, 7/16" Dia.
5.	BS071732	1	Torsion Spring
6.	HC582810	1	Socket Head Cap Screw, #10-32x3/8
7.	HY581408	2	Set Screw, #10-32x1/4
8.	7320M307	2	Machined Stud
9.	PP460019	2	Clamp Knob
10.	7720C316	1	Gripper Weldment

ADAPTER USAGE

The Stationary Gripper Arm along with the Gripping Device is used in DAP 212 Pattern Set-Up.

GRIPPING DEVICE AND HANDLES

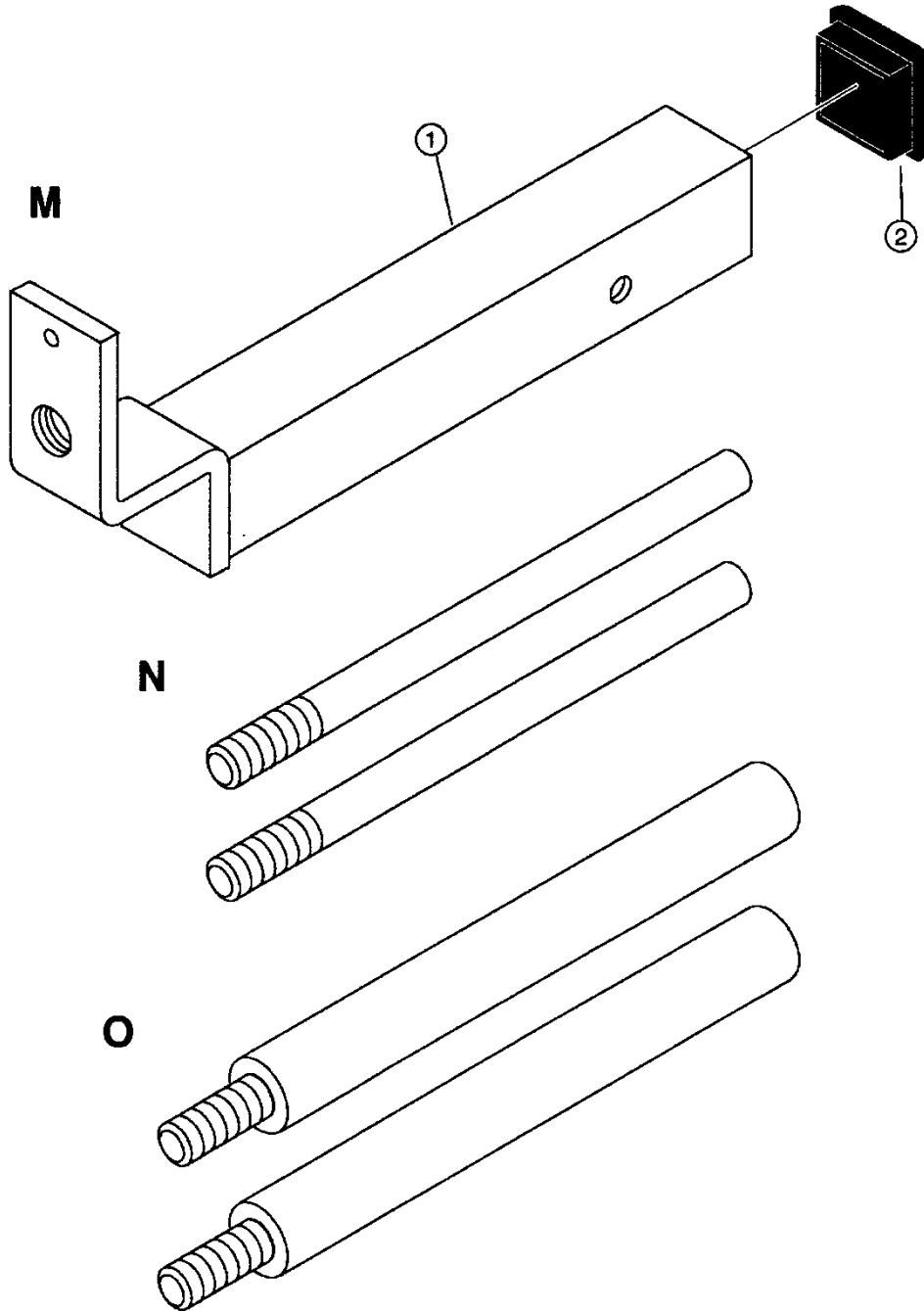

021-1

Figure 3-44 Gripping Device and Handles

REPLACEABLE PARTS

REF. NO.	PART NO.	QTY	DESCRIPTION
M	7720W320	1	Gripping Device Assembly
1.	7720W320	1	Gripping Device
2.	PP300013	1	Insert Glide, 1-1/4" sq. x 16 ga.
N	7320C302	1 pair	Handles, 1/2" Diameter
O	7320C301	1 pair	Handles, 3/4" Diameter

ADAPTER USAGE

The Gripping Device and Handles are used in DAP 212 Pattern Set-Up.

PUSH / PULL INPUT ARM

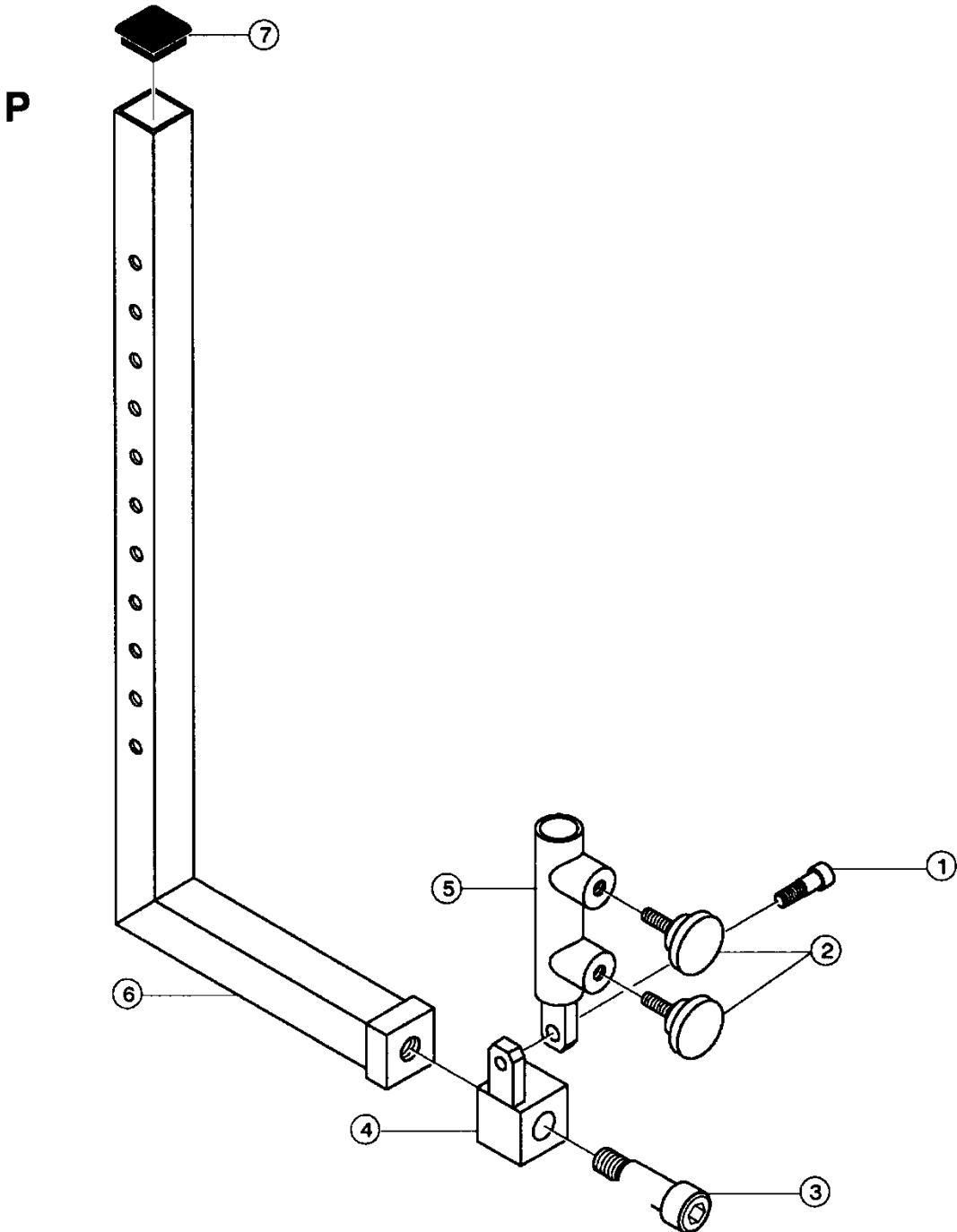

018-1E

Figure 3-45 Push / Pull Input Arm

REPLACEABLE PARTS

REF. NO.	PART NO.	QTY	DESCRIPTION
P	7720A500		Push / Pull Input Arm assembly
1.	HD383312	1	Shoulder Bolt, 3/8-16 x 1-1/16
2.	PP460012	2	Locking Knob w/Shaft
3.	HD753322	1	Shoulder Bolt, 5/8-11 x 1-3/8
4.	7720C510	1	C/Swivel Hub Weldment
5.	7720C515	1	Input Arm Receiving Tube Weldment
6.	7720W505	1	Input Tube Weldment
7.	PP300013	1	Insert Glide, 1-1/4" sq. x 16 ga.

ADAPTER UAGE

The Push / Pull Input Arm along with the Simulation Handle is used in DAP 213 Pattern Set-Up.

SIMULATION HANDLE

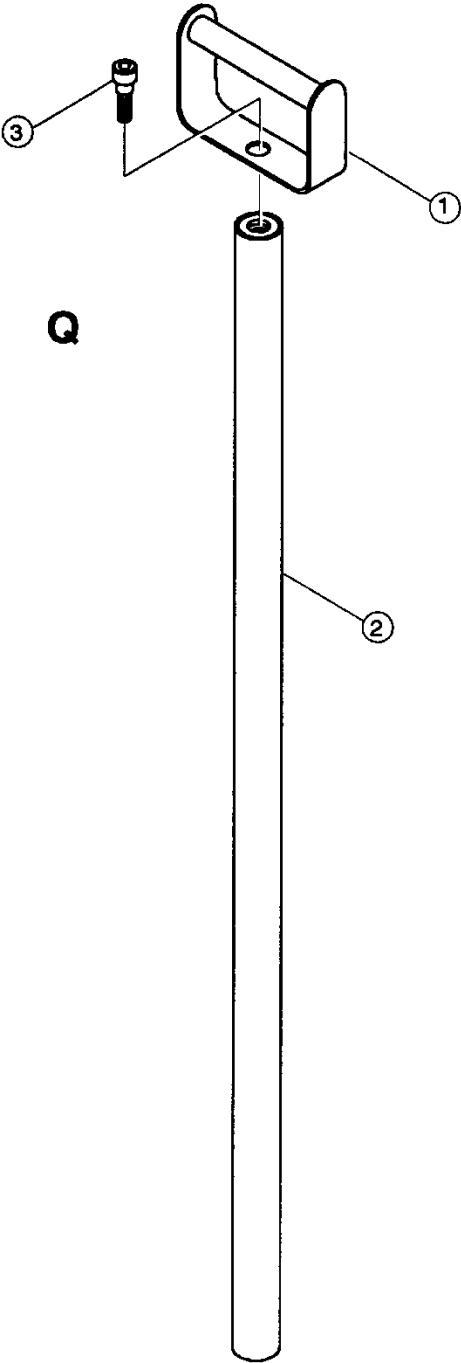

019-1E

Figure 3-46 Simulation Handle

REPLACEABLE PARTS

REF. NO.	PART NO.	QTY	DESCRIPTION
Q	7720A500		Simulation Handle Assembly
1.	7720C520	1	Simulation Handle Adapter
2.	7720C525	1	Simulation Handle Weldment
3.	HD383312	1	Shoulder Bolt, 3/8–16 x 11/16

ADAPTER USAGE

The Simulation Handle along with the Push / Pull Input Arm is used in DAP 213 Pattern Set-Up.

TEF MODULAR COMPONENT - P/N 731A001

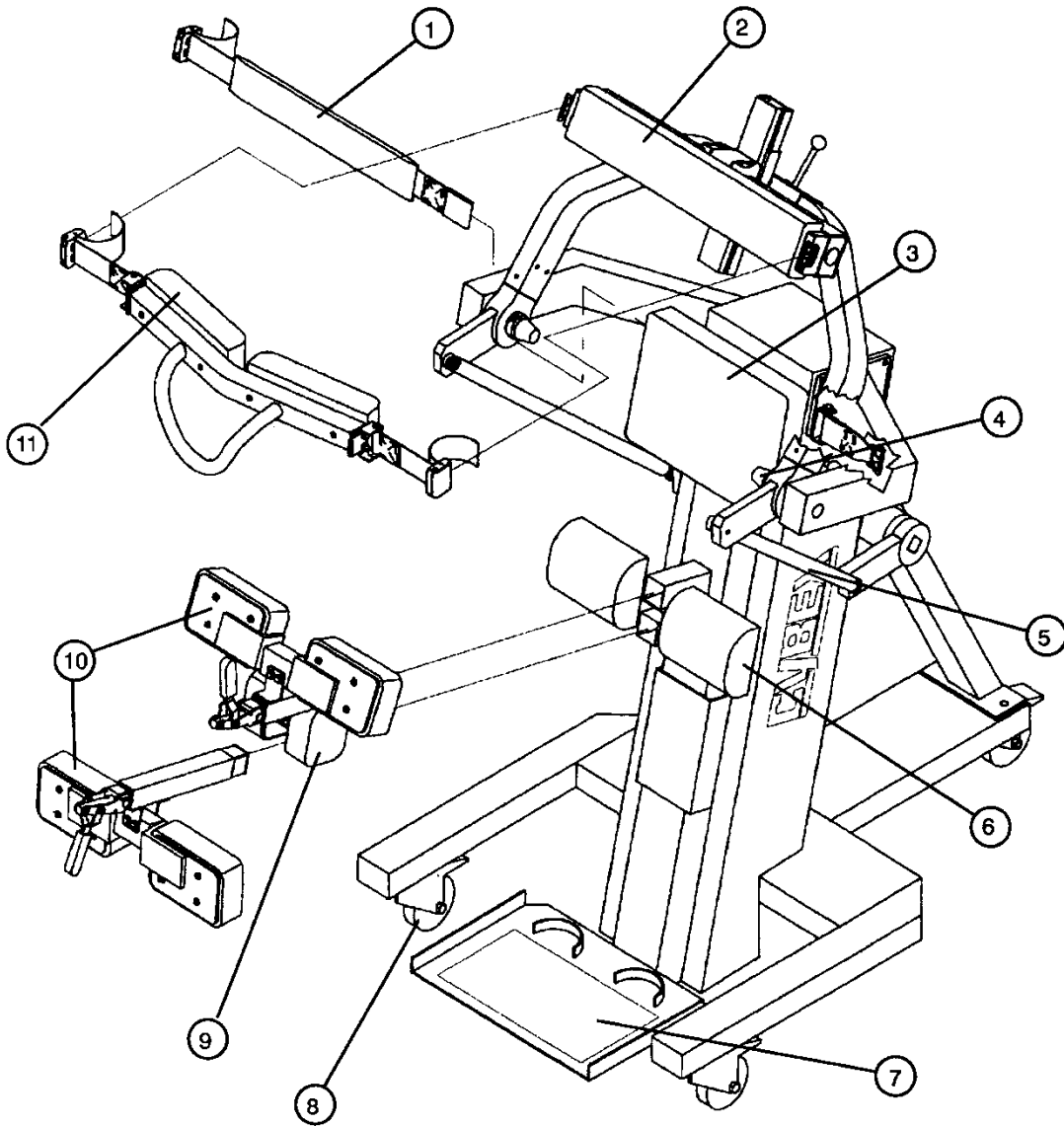

Figure 3-47 TEF Modular Component

TEF Modular Component

The TEF Modular Component is designed to test and rehabilitate the trunk musculature involved in daily lifting, carrying, and reaching, as well as posture and movement. Upon docking with the NORM System, the TEF Modular Component becomes an integral part of the CSMi Testing and Rehabilitation System.

TEF Modular Components produced prior to 1997 were equipped with an internal isolation

transformer. Starting in 1997, the isolation transformer is externally mounted. (The pre-1997 build is shown on the facing page.)

The upholstery color numbers for the TEF Modular Component are the same as for the NORM System. Refer to those part numbers (provided in Appendix E) when ordering upholstery replacements.

Replaceable Parts

REF. NO.	PART NO.	QTY	DESCRIPTION
1.	3400U216-XX	1	Pelvic Belt Pad
2.	7310S699-XX	1	Scapular Pad
3.	1750U110-XX	1	Back Cushion
4.	PR069473	2	Bumper, 1-1/2 inch
5.	731C502	2	Tie Rod
6.	1750U081-XX	2	Poplietal Pad
7.	1750M148	1	Safety Walk
8.	WB021500	3	Wheel Caster
9.	175U059-XX	2	Knee Cushion
10.	1750U067-XX	4	Thigh / Tibial Cushion
11.	3400U216-XX	2	Chest Pad

APPENDIX B. ELECTROMAGNETIC COMPATIBILITY

GUIDANCE AND MANUFACTURER'S DECLARATION – EMISSIONS

Guidance and Manufacturer's Declaration – Electromagnetic Emissions		
The NORM is intended for use in the electromagnetic environment specified below. The customer or user of the NORM should ensure that it is used in such an environment.		
Emissions Test	Compliance	Electromagnetic Environment – Guidance
RF Emissions CISPR 11	Group 1	The NORM uses RF energy only for its internal function. Therefore, its RF emissions are very low and are not likely to cause any interference in nearby electronic equipment.
RF Emissions CISPR 11	Class A or B	B
Harmonics IEC 61000-3-2	Class A,B,C,D or N/A	A
Flicker IEC 61000-3-3	Complies or N/A	Complies
	[See 6.8.3.201 a) 3) and Figure 201]	The NORM is suitable for use in all establishments, including domestic, and those directly connected to the public low-voltage power supply network that supplies buildings used for domestic purposes.
RF Emissions CISPR 14-1	Complies	The NORM is not suitable for interconnection with other equipment.
RF Emissions CISPR 15	Complies	The NORM is not suitable for interconnection with other equipment.

ELECTROMAGNETIC COMPATIBILITY

GUIDANCE AND MANUFACTURER'S DECLARATION – IMMUNITY ALL EQUIPMENT AND SYSTEMS

Guidance and Manufacturer's Declaration – Electromagnetic Immunity				
The NORM is intended for use in the electromagnetic environment specified below. The customer or user of the NORM should ensure that it is used in such an environment.				
Immunity Test	EN/IEC	60601 Test Level	Compliance Level	Electromagnetic Environment – Guidance
ESD 61000-4-2	EN/IEC	±6kV Contact ±8kV Air	As specified	Floors should be wood, concrete or ceramic tile. If floors are synthetic, the r/h should be at least 30%.
EFT 61000-4-4	EN/IEC	±2kV Mains ±1kV I/Os	As specified	Mains power quality should be that of a typical commercial or hospital environment.
Surge 61000-4-5	EN/IEC	±1kV Differential ±2kV Common	As specified	Mains power quality should be that of a typical commercial or hospital environment.
Voltage Dips/Dropout EN/IEC 61000-4-11		>95% Dip for 0.5 Cycle	As specified	Mains power quality should be that of a typical commercial or hospital environment. If the user of the NORM expects dips as specified and requires continued operation during power mains interruptions, it is recommended that the NORM be powered from an uninterruptible power supply or battery.
		60% Dip for 5 Cycles	As specified	
		30% Dip for 25 Cycles	As specified	
		>95% Dip for 5 seconds	As specified	
Power Frequency 50/60Hz EN/IEC 61000-4-8		3A/m	As specified	Power frequency magnetic fields should be that of a typical commercial or hospital environment.

ELECTROMAGNETIC COMPATIBILITY

GUIDANCE AND MANUFACTURER'S DECLARATION – EMISSIONS EQUIPMENT AND SYSTEMS THAT ARE NOT LIFE-SUPPORTING

Guidance and Manufacturer's Declaration – Electromagnetic Immunity

The NORM is intended for use in the electromagnetic environment specified below. The customer or user of the NORM should ensure that it is used in such an environment.

Immunity Test	EN/IEC Test Level	60601 Compliance Level	Electromagnetic Environment – Guidance
Conducted RF EN/IEC 61000-4-6	3 Vrms 150 kHz to 80 MHz	(V1)Vrms (E1)V/m	Portable and mobile communications equipment should be separated from the NORM by no less than the distances calculated/listed below: $D=(3.5/V1)(\text{Sqrt } P)$ $D=(3.5/E1)(\text{Sqrt } P)$ 80 to 800 MHz $D=(7/E1)(\text{Sqrt } P)$ 800 MHz to 2.5 GHz where P is the max power in watts and D is the recommended separation distance in meters. Field strengths from fixed transmitters, as determined by an electromagnetic site survey, should be less than the compliance levels (V1 and E1). Interference may occur in the vicinity of equipment containing a transmitter.
Radiated RF EN/IEC 61000-4-3	3V/m 80 MHz to 2.5 GHz		

ELECTROMAGNETIC COMPATIBILITY

RECOMMENDED SEPARATION DISTANCES BETWEEN PORTABLE AND MOBILE RF COMMUNICATIONS EQUIPMENT AND THE NORM EQUIPMENT AND SYSTEMS THAT ARE NOT LIFE-SUPPORTING

Recommended Separations Distances for the NORM			
<p>The NORM is intended for use in the electromagnetic environment in which radiated disturbances are controlled. The customer or user of the NORM can help prevent electromagnetic interference by maintaining a minimum distance between portable and mobile RF Communications Equipment and the NORM as recommended below, according to the maximum output power of the communications equipment.</p>			
Max Output Power (Watts)	Separation (m) 150kHz to 80MHz $D=(3.5/\sqrt{P})$	Separation (m) 80 to 800MHz $D=(3.5/\sqrt{E1})$	Separation (m) 800MHz to 2.5GHz $D=(7/\sqrt{E1})$
0.01	.1166	.1166	.2333
0.1	.3689	.3689	.7378
1	1.1666	1.1666	2.3333
10	3.6893	3.6893	7.3786
100	11.6666	11.6666	23.3333